

Climatronic,

- **2,8L - Engine - Motronic Multiport Fuel Injection (MFI) / 142kW, codes AHA**

from August 1998

- **2,8L - Engine - Motronic Multiport Fuel Injection (MFI) / 142kW, codes ATQ**

from August 1999

Deviate relay location and fuseplacements as well as the locations of multiple connectors see section "component locations".

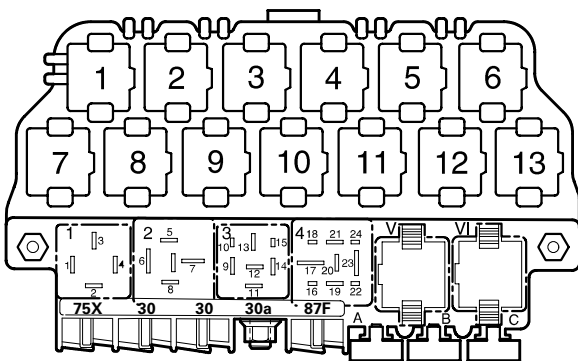

97-20676

Relay location on the thirteenfold auxiliary relay panel, above relay panel:

- 3** A/C Clutch Relay (267)

Relay panel:

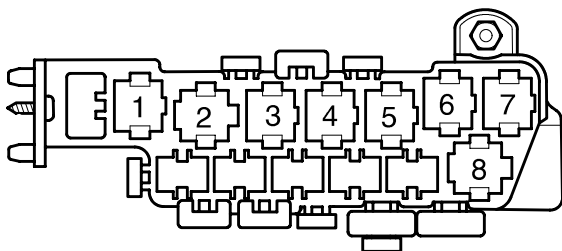

97-20515

Relay location on the eightfold auxiliary relay panel, behind relay panel:

- 5** First Speed Coolant Fan Control (FC) Relay (214)
- 8** Second Speed Coolant Fan Control (FC) Relay (213)

Note: Number in parentheses indicates production control number stamped on relay housing.

Fuse colors

30 A - green
 25 A - white
 20 A - yellow
 15 A - blue
 10 A - red
 7,5 A - brown
 5 A - beige

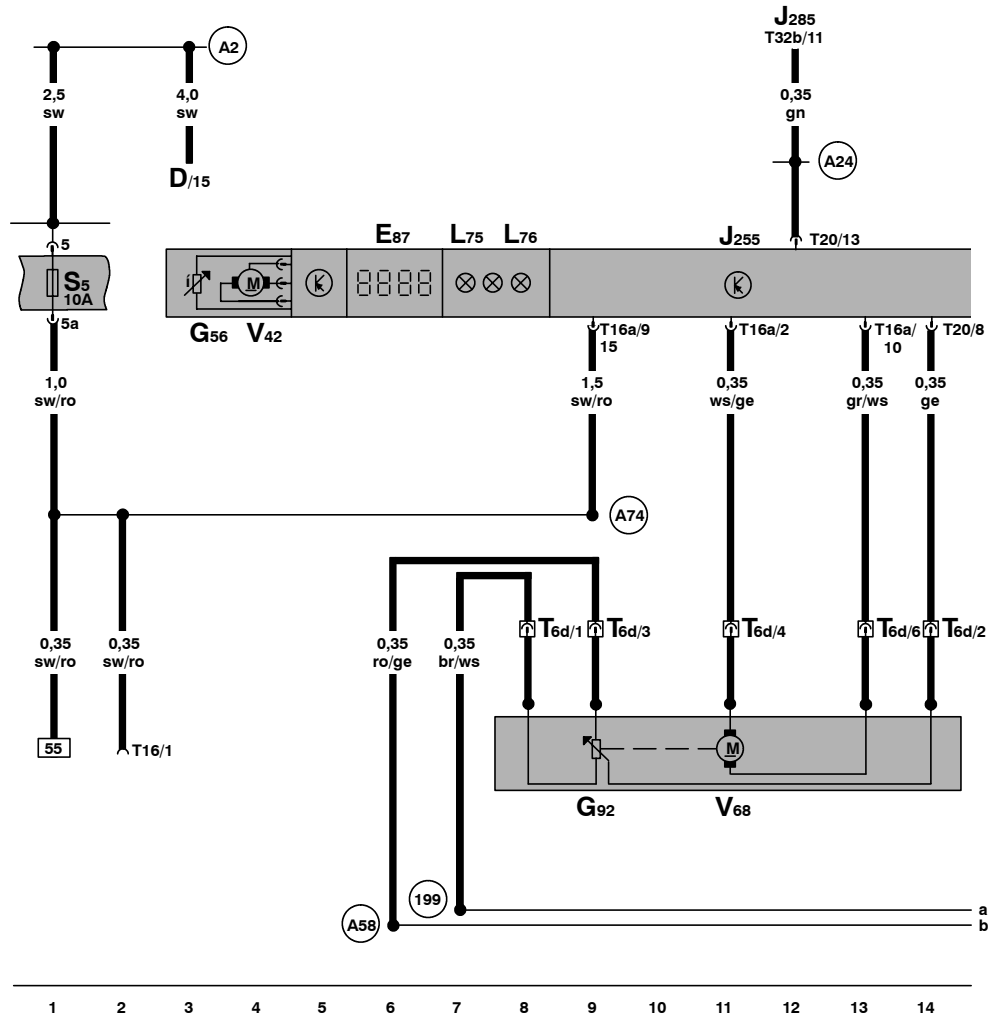

ws = white
 sw = black
 ro = red
 br = brown
 gn = green
 bl = blue
 gr = grey
 li = violet
 ge = yellow

1	2	3	4	5	6	7	8	9	10	11	12	13	14
													97-29012

- D - Ignition/Starter Switch
- E87 - A/C Control Head
- G56 - Instrument Panel Interior Temperature Sensor
- G92 - Temperature Regulator Flap Motor Position Sensor
- J255 - Climatronic Control Module
- J285 - Control module with indicator unit in instrument panel insert
- L75 - Digital Display Light
- L76 - Push Button Light
- S5 - Fuse 5 in fuse holder
- T6d - 6-Pin Connector, red, behind instrument panel, center
- T16 - 16-Pin Connector, On Board Diagnostic (OBD), below instrument panel, left
- T16a - 16-Pin Connector
- T20 - 20-Pin Connector

- T32b - 32-Pin Connector, green, on instrument cluster
- V42 - Interior Temperature Sensor Fan
- V68 - Temperature Regulator Flap Motor
- (199) - Ground connection -3-, in instrument panel wiring harness
- (A2) - plus connection (15), in instrument panel wiring harness
- (A24) - wire connection (brake system monitoring), in instrument panel wiring harness
- (A58) - Wire connection (5Volt), in instrument cluster wiring harness
- (A74) - Connector (15a - fuse 5), in instrument panel wiring harness

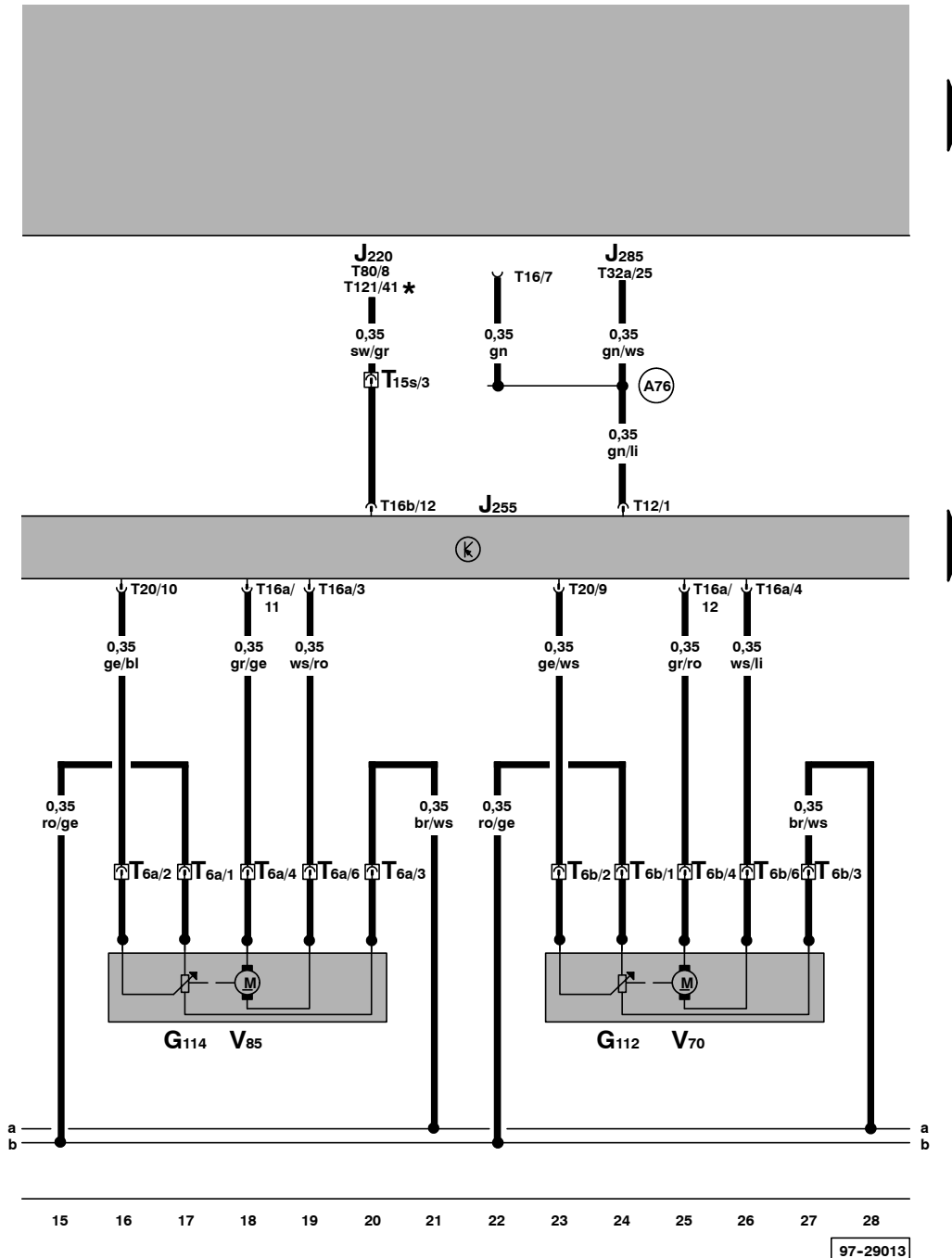

ws = white
 sw = black
 ro = red
 br = brown
 gn = green
 bl = blue
 gr = grey
 li = violet
 ge = yellow

97-29013

- G112 - Central Flap Motor Position Sensor
- G114 - Footwell/Defrost Flap Motor Position Sensor
- J220 - Motronic Engine Control Module (ECM)
- J255 - Climatronic Control Module
- J285 - Control module with indicator unit in instrument panel insert
- T6a - 6-Pin Connector, behind instrument panel, center
- T6b - 6-Pin Connector, behind instrument panel, center
- T12 - 12-Pin Connector
- T15s - 15-Pin Connector, red, on protective housing for control module, in engine compartment, left
- T16 - 16-Pin Connector, On Board Diagnostic (OBD), below instrument panel, left
- T16a - 16-Pin Connector
- T16b - 16-Pin Connector

- T20 - 20-Pin Connector
- T32a - 32-Pin Connector, blue, on Control Module with indicator unit in instrument panel insert
- T80 - Connector, 80 point, on Motronic Engine Control Module (ECM)
- T121 - Connector, 121 point, on Motronic Engine Control Module (ECM)
- V70 - Central Air Flap Motor
- V85 - Footwell/Defroster Flap Motor
- (A76) - Connector (K-diagnosis wire), in instrument panel wiring harness
- * - from August 1999

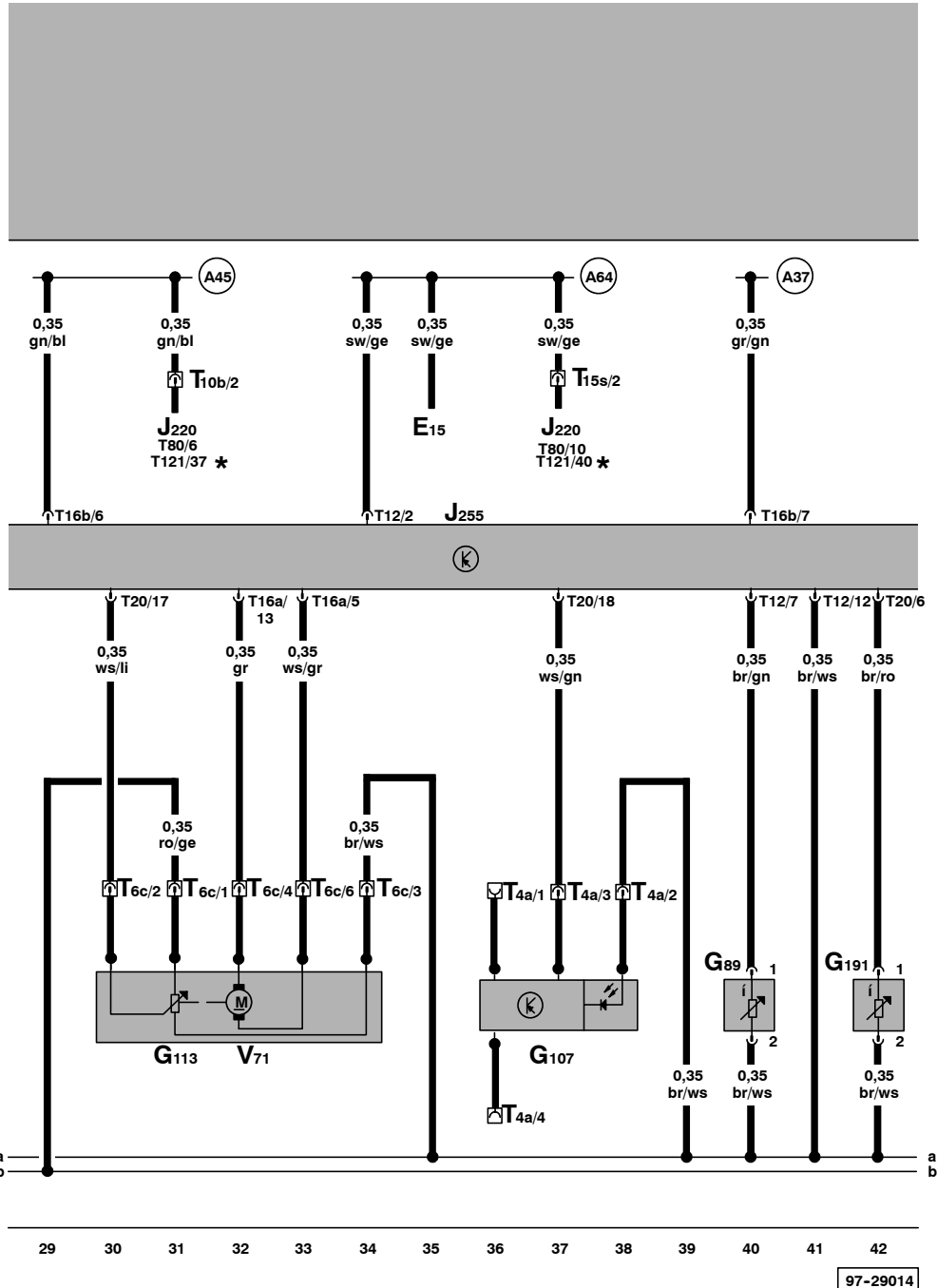

- E15 - Rear window defogger switch
- G89 - Fresh Air Intake Duct Temperature Sensor
- G107 - Sunlight Photo Sensor, on instrument panel, left
- G113 - Back Pressure Flap Motor Position Sensor
- G191 - Sender for outlet temperature, center
- J220 - Motronic Engine Control Module (ECM)
- J255 - Climatronic Control Module
- T4a - 4-Pin Connector, black
- T6c - 6-Pin Connector, black
- T10b - 10-Pin Connector, black, on protective housing for control module, in engine compartment, left
- T15s - 15-Pin Connector, red, on protective housing for control module, in engine compartment, left
- T12 - 12-Pin Connector
- T16a - 16-Pin Connector

- T16b - 16-Pin Connector
- T20 - 20-Pin Connector
- T80 - Connector, 80 point, on Motronic Engine Control Module (ECM)
- T121 - Connector, 121 point, on Motronic Engine Control Module (ECM)
- V71 - Air Flow Flap Motor
- A37 - wire connection (58a), in instrument panel wiring harness
- A45 - wire connection (RPM-signal), in instrument panel wiring harness
- A64 - Connector (30, idle boost), in instrument panel wiring harness
- * - from August 1999

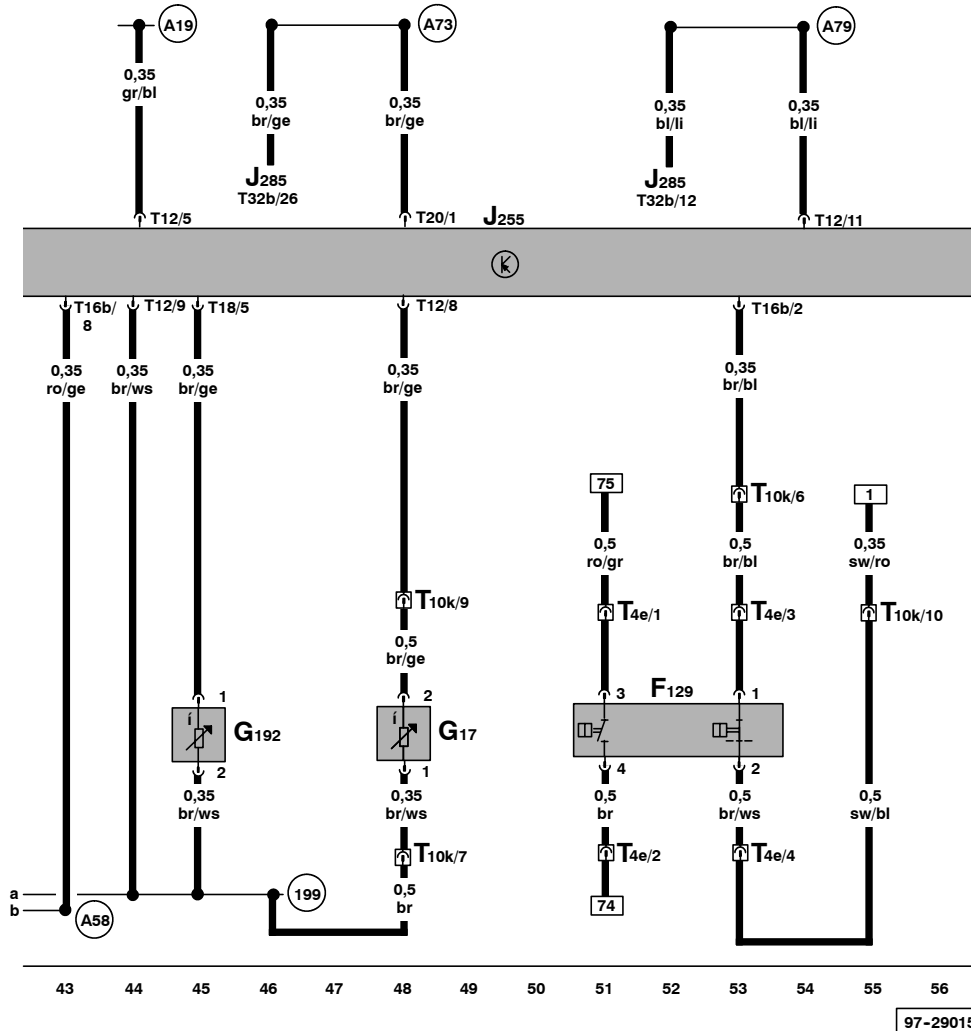

ws = white
 sw = black
 ro = red
 br = brown
 gn = green
 bl = blue
 gr = grey
 li = violet
 ge = yellow

97-29015

- F129 - A/C Pressure Switch
- G17 - Outside Air Temperature Sensor
- G192 - Sender for outlet temperature, floor outlet
- J255 - Climatronic Control Module
- J285 - Control module with indicator unit in instrument panel insert
- T4e - 4-Pin Connector, in engine compartment, left
- T10k - 10-Pin Connector, grey, connector station A-pillar, left
- T12 - 12-Pin Connector, neben der Lenksäule rechts
- T16b - 16-Pin Connector
- T20 - 20-Pin Connector
- T32b - 32-Pin Connector, green, on instrument cluster

- (A19) - wire connection (58d), in instrument panel wiring harness
- (A58) - Wire connection (5Volt), in instrument cluster wiring harness
- (A73) - Connector (outside temperature indicator), in instrument panel wiring harness
- (A79) - Connector (engine overheat warning light), in instrument panel wiring harness

- (199) - Ground connection -3-, in instrument panel wiring harness

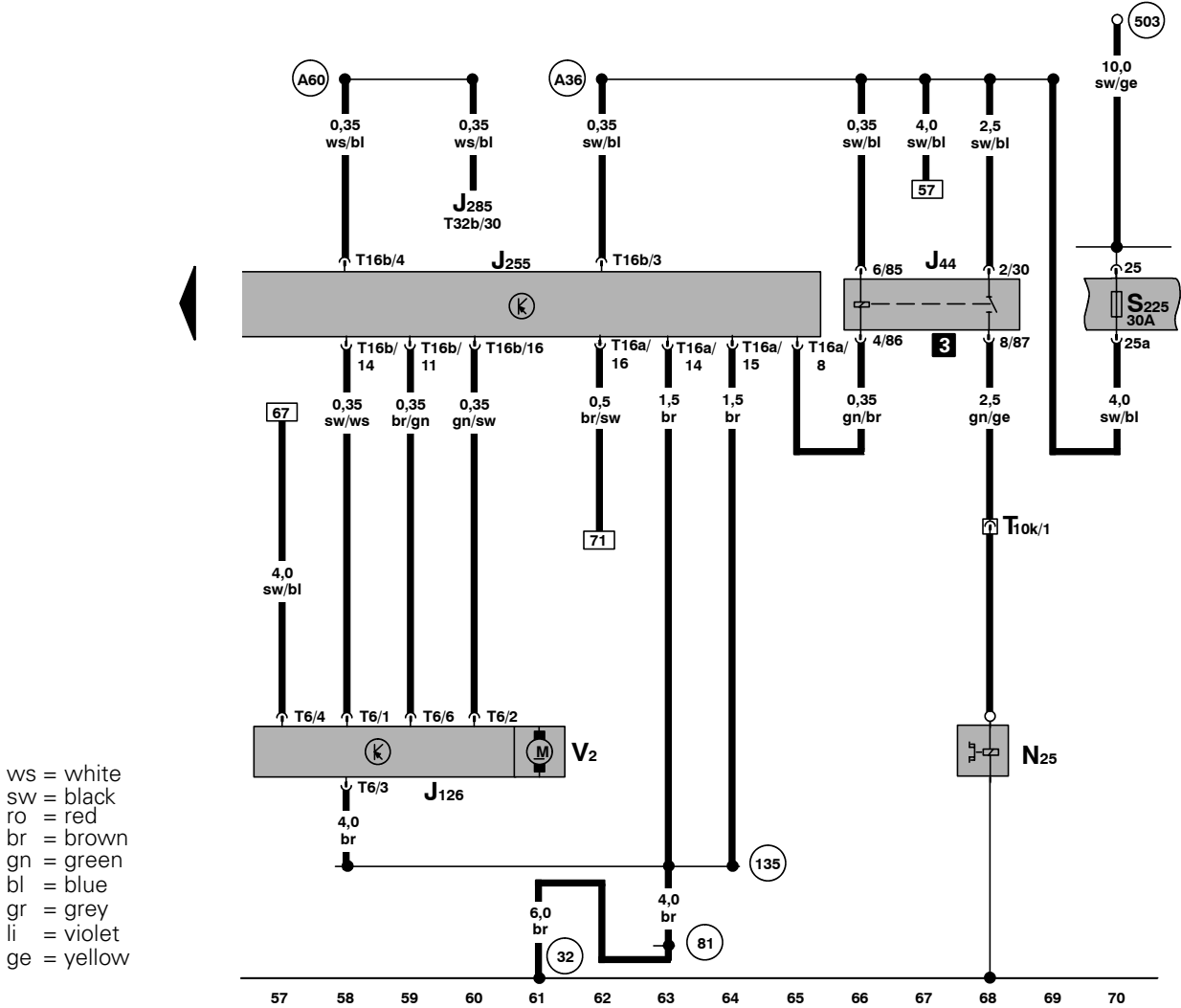

ws = white
 sw = black
 ro = red
 br = brown
 gn = green
 bl = blue
 gr = grey
 li = violet
 ge = yellow

- J44 - A/C Clutch Relay, on thirteenfold auxiliary relay panel, above relay panel, production control number (267)
- J126 - Control module for fresh air blower, behind instrument panel, right
- J255 - Climatronic Control Module
- J285 - Control module with indicator unit in instrument panel insert
- N25 - A/C Clutch
- S225 - Fuse 25 in fuse holder
- T6 - 6-Pin Connector, brown
- T10k - 10-Pin Connector, grey, connector station A-pillar, left
- T16a - 16-Pin Connector
- T16b - 16-Pin Connector
- T32b - 32-Pin Connector, green, on instrument cluster
- V2 - Fresh Air Blower

- 32 - Ground connection, behind instrument panel, left
- 81 - Ground connection -1-, in instrument panel wiring harness
- 135 - Ground connection -2-, in instrument panel wiring harness
- 503 - Screw Connection (75x), on relay panel
- A36 - wire connection (75a), in instrument panel wiring harness
- A60 - Wire connection (Vehicle speed signal), in instrument cluster wiring harness

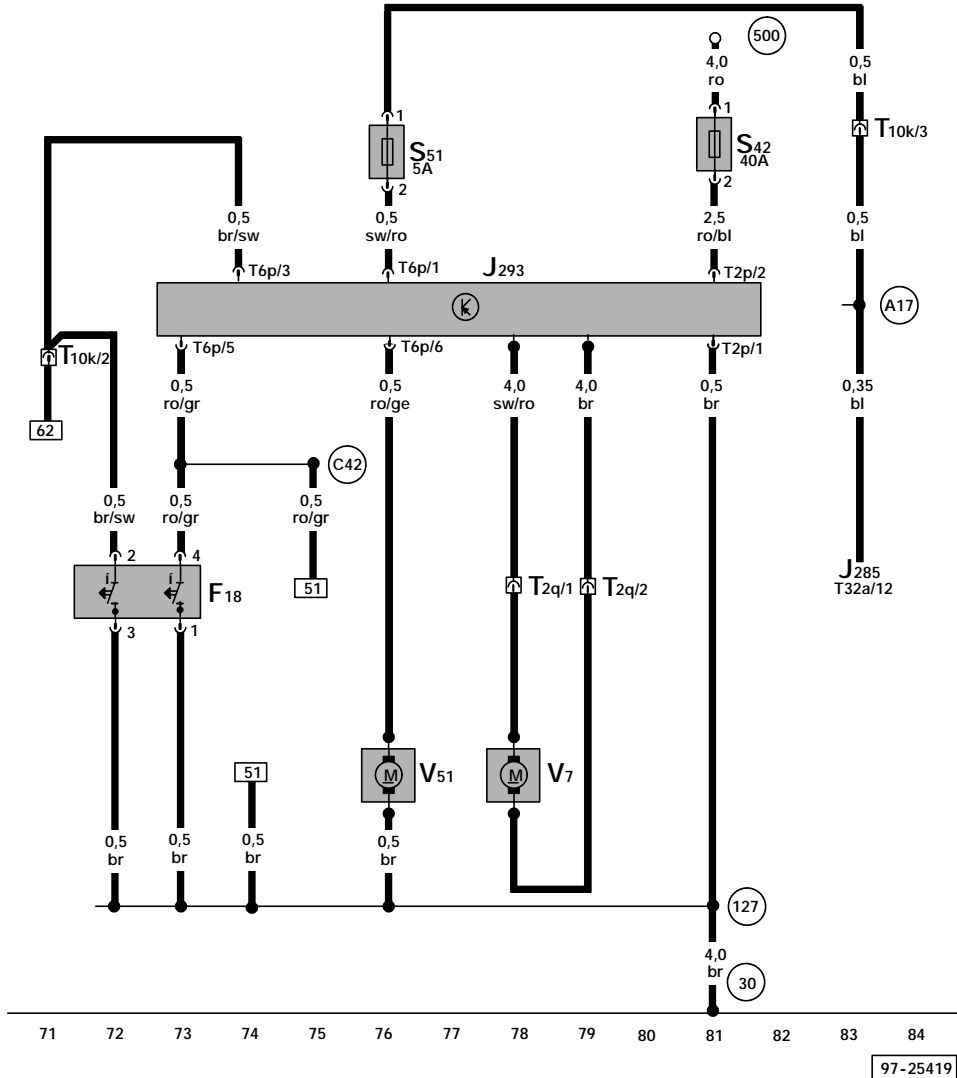

ws = white
 sw = black
 ro = red
 br = brown
 gn = green
 bl = blue
 gr = grey
 li = violet
 ge = yellow

- F18 - Coolant Fan Control (FC) Thermal Switch
- J285 - Control Module with indicator unit in instrument panel insert
- J293 - Coolant FC (Fan Control) Control Module
- S42 - Coolant Fan Fuse, on eightfold auxiliary relay panel
- S51 - Coolant Fan Fuse, on eightfold auxiliary relay panel
- T2p - Double Connector
- T2q - Double Connector, in engine compartment, left
- T6p - 6-Pin Connector
- T10k - 10-Pin Connector, grey, connector station A-pillar, left
- T32a - 32-Pin Connector, blue, on Control Module with indicator unit in instrument panel insert
- V7 - Coolant Fan

- V51 - After-Run Coolant Pump
- (30) - Ground connection -1-, beside fuse/relay panel
- (127) - Ground connection -1-, in A/C compressor wiring harness
- (500) - Screw Connection -1- (30), on relay panel
- (A17) - wire connection (61), in instrument panel wiring harness
- (C42) - Connector (fan for coolant), in wiring harness coolant