

Workshop Manual

Octavia II 2004 ➤
Octavia II 2010 ➤

Wheels, Tyres

Edition 08.2012

Protected by copyright. Copying for private or commercial purposes, in part or in whole, is not permitted unless authorised by ŠKODA AUTO A. S. ŠKODA AUTO A. S. does not guarantee or accept any liability with respect to the correctness of information in this document. Copyright by ŠKODA AUTO A. S. ©

List of Workshop Manual Repair Groups

Repair Group

44 - Wheels, tyres, vehicle geometry

ŠKODA



Protected by copyright. Copying for private or commercial purposes, in part or in whole, is not permitted unless authorised by ŠKODA AUTO A. S. ŠKODA AUTO A. S. does not guarantee or accept any liability with respect to the correctness of information in this document. Copyright by ŠKODA AUTO A. S. ©

Technical information should always be available to the foremen and mechanics, because their careful and constant adherence to the instructions is essential to ensure vehicle road-worthiness and safety. In addition, the normal basic safety precautions for working on motor vehicles must, as a matter of course, be observed.

All rights reserved.
No reproduction without prior agreement from publisher.

Contents

44 - Wheels, tyres, vehicle geometry	1
1 General points for wheels/tyres	1
2 Technical conditions for changing wheel/tyre combinations	2
3 Technical data for tyres	3
3.1 Identification markings on the tyre sidewall	3
3.2 Speed ratings for tyres	7
3.3 Undulations	8
3.4 Tyre storage	8
3.5 Tyre ageing	9
3.6 Winter tyres	10
3.7 Snow chains	11
3.8 Tyre structure	11
4 Tyre wear/mileage of the tyre	14
4.1 General notes	14
4.2 Requirements to be met by tyres	15
4.3 Wear behaviour of high-speed tyres	16
4.4 Factors influencing the service life of a tyre	16
4.5 Driving style	17
4.6 Tyre maintenance	18
4.7 Evenly worn tyres	20
4.8 Measuring tread depth	21
4.9 Unilateral wear	23
4.10 Outside shoulder wear	26
4.11 Wear in middle of tyre	27
4.12 Diagonal washout	29
5 Tyre noise	30
5.1 General notes on tyre noise	30
5.2 Saw-tooth wear	31
5.3 Flat spots	33
6 Rough running due to wheels/tyres - causes	35
6.1 Causes of rough running	35
6.2 Balancing	36
6.3 Conducting a road test before balancing wheels	36
6.4 Balancing wheel on stationary wheel balancer	37
6.5 Finish balancer	38
6.6 Radial and lateral runout on wheels and tyres	40
6.7 Checking radial and lateral runout on wheels/tyres with tyre gauge	40
6.8 Checking radial and lateral runout on wheel rim	41
6.9 Match mounting	42
6.10 Flat spots on tyres	44
7 Vehicle pulls to one side	46
7.1 General notes	46
7.2 Conicity	47
7.3 Remedies when vehicle pulls to one side	49
7.4 Strategic rotation of wheels for non-directional tyres	50
7.5 Strategic rotation of wheels having unidirectional tyres	52
8 Tyre damage	54
8.1 General information	54
8.2 Impact damage	55
8.3 Cuts	57
8.4 Damage caused by foreign bodies	57
8.5 Loss of air from tyre	57



8.6	Tyre pressure	58
8.7	Tyre damage due to insufficient tyre pressure	59
8.8	Rising tyre temperature caused by insufficient tyre pressure	60
8.9	Tyre damage due to fitting error (fitting damage)	61
9	Rolling resistance optimised tyres	64
10	Rims - basic information	65
10.1	Structure of wheel rim	65
10.2	Data on wheel rims	67
10.3	Care and maintenance of alloy wheel rims	67
10.4	Restoring alloy wheels	68
10.5	The rubber valve	69
11	Fitting wheels	71
11.1	Rotating wheels	71
11.2	Instructions for changing or fitting wheels	71
11.3	Protecting wheel centring seat against corrosion	73
11.4	Notes on use of temporary spare wheels	75
12	Wheel/tyre combinations	76
12.1	Permissible wheel-tyre combinations	77
13	Wheels, Tyres	83
13.1	Wheels, Tyres - Instructions	83
13.2	Wheel with steel rim 6J x 15 or 6,5J x 16	84
13.3	Wheel with a light alloy rim 6J x 15	85
13.4	Wheel with a light alloy rim 6.5J x 15	87
13.5	Wheel with a light alloy rim 6.5J x 16	89
13.6	Wheel with a light alloy rim 7J x 17	91
13.7	Wheel with a light alloy rim 7,5J x 18	93
13.8	Spare wheel	95

Protected by copyright. Copying for private or commercial purposes, in part or in whole, is permitted unless authorised by ŠKODA AUTO A. S. ŠKODA AUTO A. S. does not guarantee or accept any liability with respect to the correctness of information in this document. Copyright by ŠKODA AUTO A. S.

44 – Wheels, tyres, vehicle geometry

1 General points for wheels/tyres

(SRL000520; Edition 08.2012)

This information is intended to help you form an opinion as precise and accurate as possible in cases of tyre damage and other complaints.

Tyres are high-tech products that are especially adapted to the requirements of modern vehicles.

As with all highly developed technical products, tyres require proper care, maintenance and service. This is essential to ensure safety, performance and comfort for the entire service life of the tyre.

Vehicle safety is the top priority. With regard to the various operating conditions such as

- different speed ranges,
- winter / summer use,
- wet / dry road,

the optimal compromise for vehicle safety must be found.

Every tyre is subjected to a wide range of different driving conditions over its entire service life. It is therefore important that the basic requirements for ensuring optimal tyre performance are met.

Proper adjustment of the axle geometry during wheel alignment is an important prerequisite for ensuring the maximum service life of the tyre. The wheel alignment must always be within the specified tolerance range.

Axle alignment ⇒ Axles, steering; Rep. gr. 44



Note

Tyre damage can have various causes. It is therefore very important that one determines whether the problem has been caused by the tyre or by other components.

Normal wear and tear on a tyre will alter its characteristics. Rolling noises or rough running can be the result of such wear. These are simply the symptoms of normal wear and tear and do not constitute damage in the sense of the tyre being defective. You can take measures to eliminate the symptoms at least to some degree. However, in some cases it may not be possible to eliminate tyre noise 100%.



2 Technical conditions for changing wheel/tyre combinations

- The wheel and tyre combinations and changes listed in the tables of the individual vehicles refer exclusively to Škoda genuine rims.
- Approval of wheel and tyre combinations or a change to rims from the accessories trade is not possible with the parts certificate attached here.
- Only tyres of the same size and type may be fitted to the vehicle with front-wheel drive, however the same brand and tread pattern must always be fitted to wheels on the same axle. It is exceptionally allowed to use a different tyre temporarily in the event of breakdown. Take into account a change in driving and braking behaviour.
- Only tyres of the same size, type, brand and tread pattern may be fitted to the vehicle with four-wheel drive. It is exceptionally allowed to use a different tyre temporarily in the event of breakdown. Take into account a change in driving and braking behaviour.
- Use wheel bolts with spherical collar and a thread of M14 x 1.5 - tightening torque: 120 Nm.
- Also observe the national legislation.
- Tubeless radial tyres may only be fitted to rims with a safety hump feature on the shoulder.
- Tyres with run-flat properties (reinforced side walls) may only be used on the model Škoda Octavia.
- If the wheel and tyre combinations listed are used, the associated tyre inflation pressures must be adhered to. The tyre inflation pressures for summer tyres can be found on the sticker on the inside of the tank flap or in the tables of the individual vehicles.
- Sufficient clearance to the wheels and tyres at parts of the wheel housing, suspension and braking system is assured if the notes and specifications established in the parts certificate are observed in all operating conditions.
- Unless otherwise stated, snow chains may only be fitted to the drive wheels. On all four-wheel drive vehicles, however, only the front wheels may be fitted with snow chains.

3 Technical data for tyres

Lettering on the sidewall of the tyre ⇒ [page 3](#)

Speed index ⇒ [page 7](#)

Constrictions ⇒ [page 8](#)

Tyre storage ⇒ [page 8](#)

Tyre ageing ⇒ [page 9](#)

Winter tyres ⇒ [page 10](#)

Snow chains ⇒ [page 11](#)

Tyre structure ⇒ [page 11](#)

3.1 Identification markings on the tyre sidewall

Example: Continental ContiPremiumContact 2

1 - Size code

- e.g. 205/55 R16
⇒ [page 4](#)

2 - Position of TWI (Tread Wear Indicators)

3 - Manufacturer (trade name)

4 - Construction

- Radial - radial cord direction in carcass
- Tubeless - code for tubeless tyres

5 - Load capacity index/speed rating

- e.g. 91 ⇒ [page 4](#)
- e.g. H ⇒ [page 4](#)

6 - Specified direction of rotation/installation for tyre

7 - Maximum permissible load

- Data for North America

8 - Maximum permissible tyre pressure

- Data for North America

9 - Number of plies in the tread center and the sidewall as well as information about the material

10 - E number = Approval number

- Tyre complies with European guidelines

11 - Manufacturer code/date of manufacture

- Identification number for manufacturer's plant, tyre size and tyre model
- Tyre ageing/date of manufacture ⇒ [page 9](#)

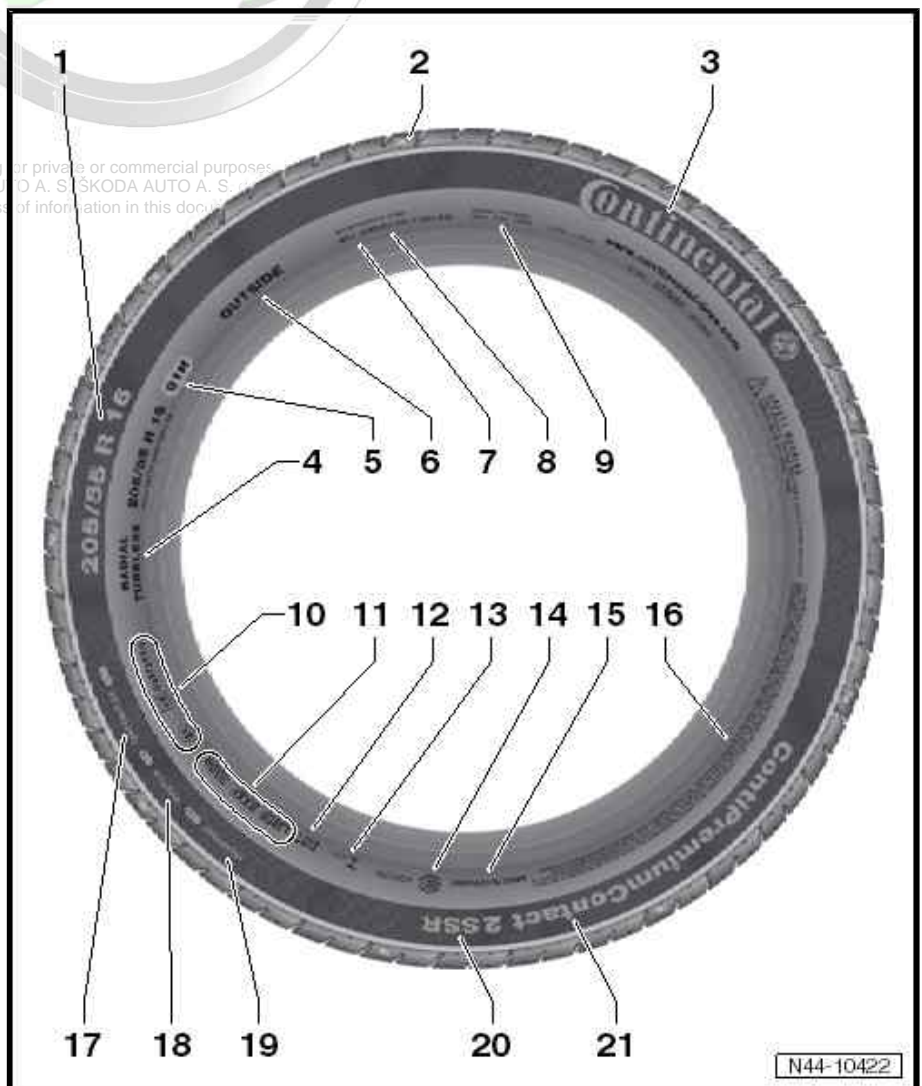

**12 - DOT - Department of Transportation USA**

- Tyre meets the standards of the Department of Transportation of the United States of America

13 - Marking for Brazil**14 - Marking for China****15 - Country of origin**

- e.g. manufactured in Germany (Made in Germany)

16 - Safety instructions for use or fitting of tyre**17 - Relative expected service life - abrasion resistance**

- based on a US standard test

18 - Rating of wet-braking traction, A, B or C

- according to a US test

19 - Rating of temperature resistance, A, B or C

- according to a US test

20 - Identifying tyres with run-flat properties

- e.g. self-supporting run-flat
- Identifying tyres with run-flat properties

21 - Tread pattern

- e.g. ContiPremiumContact

3.1.1 Explanation of tyre markings

ŠKODA



Protected by copyright. Copying for private or commercial purposes, in part or in whole, is not permitted unless authorised by ŠKODA AUTO A. S. ŠKODA AUTO A. S. does not guarantee or accept any liability with respect to the correctness of information in this document. Copyright by ŠKODA AUTO A. S. ©



Tyre size

Marking, e.g. 165/70 R14 81T	Explanation
165	Tyre width (mm)
70	Aspect ratio between height - width (%)
R	Tyre construction (radial)
14	Rim diameter (inch)
81	Load rating-index (Load index)
T	Speed rating code - speed index
M + S	Winter tyres

Manufacturing date

Manufacturing date	Explanation
DOT ... 0807	Manufactured during week 8 of 2007 (08 = 8th calendar week, 07 = year 2007)

ŠKODA

Speed rating index/maximum speed

Speed rating index	Maximum speed in km/h
L	120
M	130
N	140
P	150
Q	160
R	170
S	180
T	190
U	200
H	210
V	240

Protected by copyright. Copying for private or commercial purposes, in part or in whole, is not permitted unless authorized by ŠKODA AUTO A. S. ŠKODA AUTO A. S. does not guarantee or accept any liability with respect to the correctness of information in this document. Copyright by ŠKODA AUTO A. S.



Speed rating index	Maximum speed in km/h
ZR	above 240
W	270
Y	300

Load rating code/load index (LI)

The load rating can be found on the sidewall of the tyre. It provides information about the maximum load that the tyre can bear.

The load rating is included in the size designation of the tyre (e.g. 195/65 R15 91T). It is indicated on the tyre as a code according to ETRTO. The following table shows the load rating codes used with the corresponding load capacity of the tyres.

Load rating code	maximum load of tyre in kg
75	387
78	425
79	437
80	450
81	462
82	475
83	487
84	500
85	515
86	530
87	545
88	560
89	580
90	600
91	615
92	630
93	650
94	670
95	690

ŠKODA



Protected by copyright. Copying for private or commercial purposes, in part or in whole, is not permitted unless authorised by ŠKODA AUTO A. S. ŠKODA AUTO A. S. does not guarantee or accept any liability with respect to the correctness of information in this document. Copyright by ŠKODA AUTO A. S. ©



Load rating code	maximum load of tyre in kg
96	710
97	730
98	750
99	775
100	800
101	825
102	850
103	875
104	900
110	1060
112	1120

3.2 Speed ratings for tyres

The speed rating (e.g. “T”) following the size of the tyre (e.g. 185/65 R 14 86T) indicates the maximum permitted speed (v_{max}) of the tyre.

The tyres for the vehicle must be selected so that their maximum permitted speed is greater than the maximum speed that the vehicle (“based on model”) can attain.

Determine the minimum speed symbol of the tyre

If your vehicle has an EC type approval, the maximum speed for all vehicles is calculated as follows:

$$v_{max} = 1.05 \times v_{ght}$$

Copying for private or commercial purposes, in part or in whole, is not permitted unless authorised by ŠKODA AUTO A. S. ŠKODA AUTO A. S. does not guarantee or accept any liability

Example: specified maximum speed $v = 172$ km/h

$$v_{max} = 1.05 \times 172 \text{ km/h} = 180.60 \text{ km/h}$$

In this example, a tyre with the speed rating “T” or higher must be used.

It is permitted to use tyres with a higher speed rating. The same applies to tyres with a higher load index.



Note

For the letter “v”, enter the maximum speed given in field “T” of part I or II of the registration document or under number 6 of the vehicle documentation This calculation is necessary because all vehicles, for technical reasons, achieve different maximum speeds within a legally permitted tolerance.



3.3 Undulations

Radial depressions are slight concavities in the tyre sidewall.

They run from the bead towards the shoulder of the tyre.

The cause is the accumulation of material at the joints of the tyre components.

Undulations have no effect on:

- ◆ Safety
- ◆ Service life
- ◆ Handling or other characteristics of the tyre

Undulations are visible to varying extents. It is not necessary to inspect the tyre or remove it from the rim.



Note

Modern steel belted tyres are constructed with single-ply side walls to save weight. The sidewall components consist of long strips before they are joined together to form a tyre. They must overlap at the joints. Consequently, slight irregularities or waves are created in the area of the overlapping parts. The overlaps are easier to see from the outside due to the single-ply construction.

3.4 Tyre storage

Storage room

The conditions in the tyre storage room have to be

- dark
- dry
- cool and
- ventilated



WARNING

Stored tyres must not come in contact with fuel, oil, grease or chemicals under any circumstances. Otherwise, the material in the tyre will be damaged by chemical reactions which are not always visible.

As a result, dangerous situations can occur when the car is driven.

Protected by copyright. Copying for private or commercial purposes, in part or in whole, is not permitted without the prior written consent of SKODA AUTO A. S. SKODA AUTO A. S. does not warrant or accept any liability for the content of this document.



Of course, tyre damage occurs only if the tyre is in contact with the chemical for a relatively long time. If a few drops of fuel land on a tyre during a fill up, this is of no concern.

Storing complete wheels

Tyres mounted on wheels can be stored flat, stacked one upon the other. In this case, it is important to ensure that the tyres are clean and dry. The inflation pressure should be increased to a maximum of 3 bar.

Storing tyres without rims

Tyres without wheels are best stored standing vertically. If tyres are stacked for a long period of time, they will be pressed together quite considerably and the tyre will then be more difficult to fit. If tyres are stored standing vertically, it is recommended to turn them every 14 days to avoid flat spots.

3.5 Tyre ageing

- ◆ Even visually flawless, like new or hardly used tyres with sufficient tread depth, which are older than 6 years, may have significant deterioration in driving performance due to ageing.
- ◆ Tyre test results show that with a constantly ongoing development process, better tyres emerge due to the use of new rubber compounds, modern materials, in combination with improvements to the tread design and tread geometry.
- ◆ The requirements of modern, sophisticated vehicles, and the growing demand of customers for an economical tyre product that offers the ultimate in safety, comfort and driving dynamics, can only be met with tyres of the latest technology.
- ◆ The requirements of modern, sophisticated vehicles, and the growing demand of customers for an economical tyre product that offers the ultimate in safety, comfort and driving dynamics, can only be met with tyres of the latest technology.
- ◆ Tyres age as a result of physical and chemical processes, which can impair the function of the tyres. Tyres which are stored for longer periods of time harden and become brittle faster than tyres which are constantly in use on a vehicle.
- ◆ Older tyres may develop hairline cracks as a result of ageing.
- ◆ When tyres are in regular use, the constant flexing activates softeners in the rubber, preventing hardening and the development of cracks.
- ◆ It is therefore important to take into account not only the tread depth, but also the age of the tyres which are not permanently in use.
- ◆ The tyre age can be determined from in the DOT designation, which includes the production date of the tyre.

Example of a DOT number up to 31.12.1999

DOT	5	0	9	<
				stands for 199_
				Last digit is production year
				Calendar week

In this example, the production date is the 50th week of 1999.



Example of a DOT number as of 01.01.2000

DO	0 1	0 0
T		
		Last 2 digits is production year
	Calendar week	

In this example, the production date is the 1st week of 2000.

Recommendation

- ◆ It is recommended not to use summer and winter tyres which are older than 6 years anymore. The original properties deteriorate due to the ageing process. Winter tyres especially lose their adhesion properties.
- ◆ When new tyres are fitted, the spare tyre may also be used if it is in flawless condition and is not more than 6 years old. The age of the tyre has a great influence on the high-speed capability of the tyre. It is possible to combine a spare tyre which is several years old with new tyres; however, this can have an adverse influence on vehicle handling.
- ◆ Tyres are constantly being further developed, which can lead, for example, to slight changes in the rubber compound, even if the tyres are of the same make, size and tread pattern.
- ◆ All new vehicles are factory-fitted with four identical tyres and wheels.

Replacing tyres

The tyres must always be replaced, when:

- the legal minimum tread depth of 1.6 mm is reached
- mechanical damage to the tyre is visible

3.6 Winter tyres

The following always applies:

All tyre sizes listed in the vehicle documents can also be used as winter tyres!

The handling characteristics may be affected by the use of winter tyres and the possible change in the dimensions of the wheel and tyre. Therefore, when using winter tyres, you must adapt your speed to the changed handling characteristics and to the road conditions.

To achieve the best possible handling, winter tyres must be fitted on all wheels.

If the vehicle is equipped with rims other than the factory-fitted rims, you must take the following into consideration when you fit winter tyres:

- ◆ Wheels and wheel bolts are matched!
- ◆ Whenever the wheels are changed, corresponding wheel bolts of the correct length and with the correctly shaped spherical cap are used. The secure fit of the wheels and the functioning of the brakes depends upon this!

- ◆ Winter tyres with a tread depth of less than 4...5 mm are only partially suitable for winter use.
- ◆ Some countries require winter tyres to have a tread depth of at least 4 mm.
- ◆ We recommend that winter tyres be replaced after no more than 6 years. The special „winter properties“ of these tyres decline with age, regardless of how much they are used.

Vehicles with tyre pressure control

On vehicles with tyre pressure control, the tyre inflation pressure has to be resaved or matched when changing over between summer and winter tyres ⇒ Operating instructions .

Note

- ◆ *If winter tyres are used with a lower speed rating than the maximum permissible driving speed, it has to be pointed out with a sticker providing an additional note which must be fixed in the field of vision of the driver.*
- ◆ *The information given on the sticker determines the maximum permissible driving speed for the winter tyres fitted, which must not be exceeded during the operation of the vehicle.*
- ◆ *The note on the sticker can be replaced with the system installed in the vehicle for life (for example the onboard computer) ⇒ Operating instructions .*
- ◆ *Also observe the national legislation.*

3.7 Snow chains

Snow chains must be fitted to driven wheels only.

On all four-wheel drive vehicles, however, only the front wheels may be fitted with snow chains.

It is not possible to use snow chains with all wheel and tyre combinations ⇒ [page 77](#) .

The maximum speed permitted by law when driving with snow chains is 50 km/h.

Snow chains should be removed when there is no snow on the road. There is no point in having them on the wheels, as they adversely affect the vehicle's handling. It causes unnecessary stress on the tyres and above average wear on the chains.

unless authorised by ŠKODA AUTO A. S. ŠKODA AUTO A. S. does not guarantee or accept any liability with information in this document. Copyright by ŠKODA AUTO A. S. ©

3.8 Tyre structure

Cross-section of a steel belted radial tyre



- 1 - Tread bar
- 2 - Tread groove
- 3 - Tread
- 4 - Nylon bandage
- 5 - Belt ply
 - ❑ typically made of steel
- 6 - Bead bundle
 - ❑ consists of steel wires, which are vulcanized in rubber
 - ❑ ensures the firm fit of the tyre onto the rim
- 7 - Bead booster
- 8 - Rim flange protection
 - ❑ protection against chafing of the rim and the tyre, such as curb contact
 - ❑ Tyres with rim flange protection are marked with the abbreviation MFS

ŠKODA

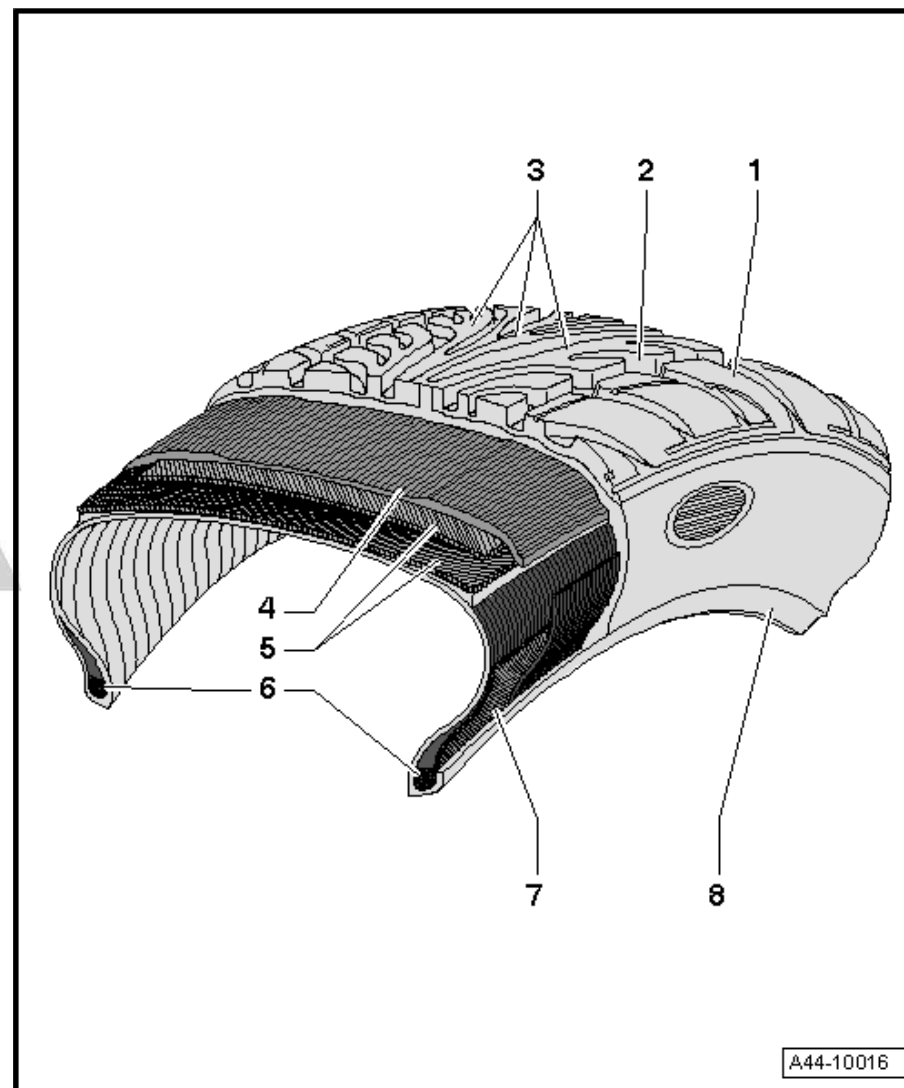



The nylon bandage -4-, belt plies -5-, bead cores -6- and bead boosters -7- form the carcass. The carcass is the "primary structure" of the tyre body.

SKODA



Protected by copyright. Copying for private or commercial purposes, in part or in whole, is not permitted unless authorised by ŠKODA AUTO A. S. ŠKODA AUTO A. S. does not guarantee or accept any liability with respect to the correctness of information in this document. Copyright by ŠKODA AUTO A. S. ©



ŠKODA

4 Tyre wear/mileage of the tyre

General points ⇒ [page 14](#)

Demands on the tyre ⇒ [page 15](#)

Wear behaviour of high-speed tyres ⇒ [page 16](#)

Influences which effect the service life of the tyre ⇒ [page 16](#)

Way of driving ⇒ [page 17](#)

Tyre maintenance ⇒ [page 18](#)

Evenly worn tyres ⇒ [page 20](#)

Measuring tyre tread depth ⇒ [page 21](#)

Unilateral wear ⇒ [page 23](#)

Outside shoulder wear ⇒ [page 26](#)

Wear in middle of tyre ⇒ [page 27](#)

Diagonal washout ⇒ [page 29](#)



4.1 General notes

A tyre has to meet numerous requirements ⇒ [page 15](#) .

Different types of tyres meet these requirements to varying degrees.

Depending on the conditions in which the tyres are used and on the type of vehicle, some requirements will be more important than others.

H, V, and Z tyres for “high-performance vehicles” are expected to have good grip on wet and flooded roads. However, mileage performance cannot be as good for tyres of this type as it is, for example, in the case of S or T tyres.

Protected by copyright. Copying for private or commercial purposes, in part or in whole, is not permitted unless authorised by ŠKODA AUTO A. S. ŠKODA AUTO A. S. does not guarantee or accept any liability with respect to the correctness of information in this document. Copyright by ŠKODA AUTO A. S. ©



4.2 Requirements to be met by tyres

- A - Wet braking properties
- B - Driving comfort
- C - Steering accuracy
- D - Driving stability
- E - Tyre weight
- F - Life expectancy
- G - Rolling resistance
- H - Aquaplaning

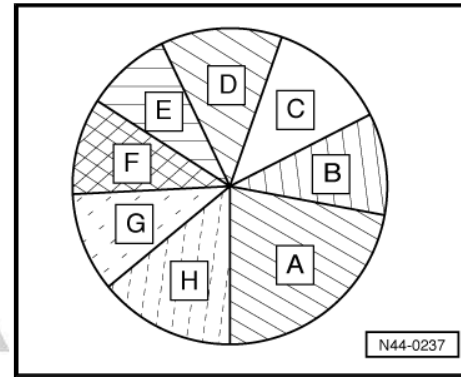

The pie chart illustrates to what extent the tyre meets the various requirements. The tyre in this example, with its specific structure and rubber composition, would meet the requirements A...H.

Improving one of the characteristics will have a negative effect on one of the others.

Example:

An improvement in wet braking properties -A- leads to a reduction in driving comfort -B-, rolling resistance -G- and life expectancy -F-.

The life expectancy of passenger vehicle tyres does not just depend on the rubber composition and design of a tyre. The conditions for use, the vehicle-specific circumstances and driving style have a heavy influence on the service life of a tyre.

Modern vehicles enable comfortable and economic driving, but also a more "sporty" driving style. A tyre life of 5,000 to 40,000 km or more is possible.



Note

Protected by copyright. Copying for private or commercial purposes, in part or in whole, is not permitted unless authorised by ŠKODA AUTO A. S. ŠKODA AUTO A. S. does not guarantee or accept any liability with respect to the correctness of information in this document. Copyright by ŠKODA AUTO A. S.

The driving style is the most important influencing factor as regards the service life of a tyre.



4.3 Wear behaviour of high-speed tyres

These tyres are designed for very high speeds. When developing these tyres, good grip in wet conditions is the main objective. The tread compositions do not have the same wear resistance as T and H tyres for lower speeds.

The life expectancy of high-speed tyres is therefore considerably lower in comparable conditions of use.

4.4 Factors influencing the service life of a tyre

The following factors influence a tyre's service life to varying degrees.

Driving style:

- ◆ Speed ⇒ [page 17](#)
- ◆ Braking ⇒ [page 17](#)
- ◆ Acceleration ⇒ [page 17](#)
- ◆ Driving through curves ⇒ [page 18](#)

Additional information about driving style

Maintenance:

- ◆ Tyre pressure

Additional information about maintenance

Environment:

- ◆ Road surface
- ◆ Ambient temperature and climate

Vehicle:

- ◆ Weight
- ◆ Dynamic toe and camber settings

Tyre use:

- ◆ Speed range

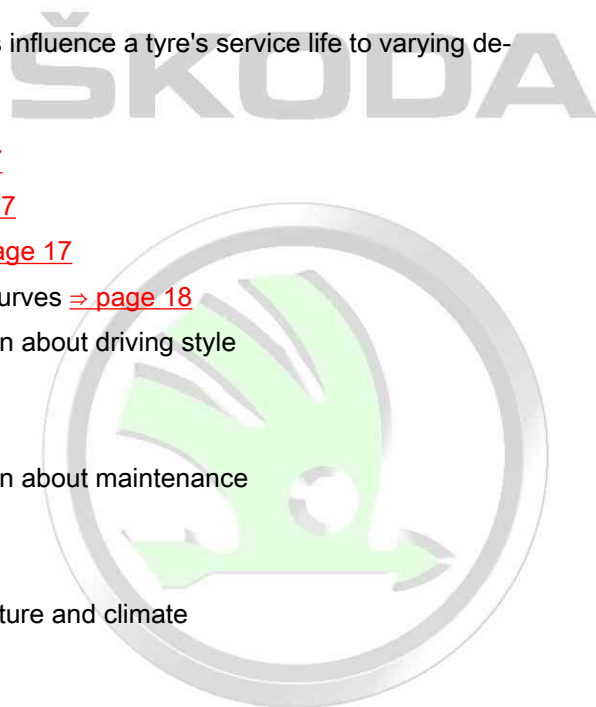

Use of this document for private or commercial purposes, in part or in whole, is not permitted unless authorised by ŠKODA AUTO A. S. ŠKODA AUTO A. S. does not guarantee or accept any liability with respect to the correctness of information in this document. Copyright by ŠKODA AUTO A. S. ©

◆ Wet or dry

Tyre type:

Winter/summer

4.5 Driving style

I. Steady driving without deceleration or acceleration

Example:

Speed (km/h)	Wheel slip	Wear
100	1	1
180	3	9

II. Braking

Most wear is caused during braking.

Example: Braking from a speed of 50 km/h

Braking distance (m)	Deceleration (m/s ²) ¹⁾	Wheel slip	Wear
Vehicle allowed to roll to a stop		0	0
100	0,1 × g	4	1
50	0.2 × g	8	4
12,5	0.4 × g ²⁾	32	2000 - 3000

1) g = Freefall acceleration: 9,81 m/s²

2) 0.4 × g corresponds to heavy braking

Protected by copyright. Copying for private or commercial purposes, in part or in whole, is not permitted unless authorised by ŠKODA AUTO A. S. ŠKODA AUTO A. S. does not guarantee or accept any liability for the correctness of the information in this document. Copyright by ŠKODA AUTO A. S. ©

III. Acceleration

Slip caused when driving off gently is approximately the same as that caused when driving at a constant speed of 100 km/h.

Example:



	Wheel slip	Wear
Driving off gently	1 - 2	1
Driving off normally	7 - 8	5
Driving off with wheels spinning	20 or more	100 - 200

IV. Driving through curves

A »»sporty«« driving style and driving at higher speeds also cause greater wear when driving through corners.

In practice, this means that wear is increased 16-fold when the cornering speed is doubled. This is called »speed surcharge«.

Example: Driving through a curve with a radius of 150 m

Speed (km/h)	Lateral acceleration (m/s ²) ¹⁾	Wear
50	1 = 0,13 × g	1
80	2,5 = 0,33 × g	6,5
100	4 = 0.53 × g	16

¹⁾ g = Gravitational acceleration: 9,81 m/s²

4.6 Tyre maintenance

Tyre pressure

The weight of the vehicle causes the tyre contact area to flatten. This in turn causes the running surface and the entire ply of the tyre to be continually deformed when a tyre is rolling. If the tyre is underinflated, the amount of flex is higher, resulting in a greater increase in heat and increased rolling resistance. This then leads to increased wear and poses a greater safety risk.

Example: Specified standard tyre pressure with cold tyres, according to vehicle load

Tyre pressure (bar)	Tyre pressure (%)	Tyre life (%)
2,3	100	100



Tyre pressure (bar)	Tyre pressure (%)	Tyre life (%)
1,9	80	85
1,4	60	60
1,0	40	25

If tyre pressure is too high, this will result in poor rolling comfort and increased wear across the centre of the tread. We recommend always to maintain the tyre pressure specified by the manufacturer.

i Note

- ◆ *The diagrams shown are not applicable in all cases.*
- ◆ *They are intended merely to give an idea of the wear rates of tyres on the front and rear axles and with front-wheel drive and four-wheel drive.*
- ◆ *The tyre service life may differ significantly, depending on operating conditions and chassis.*

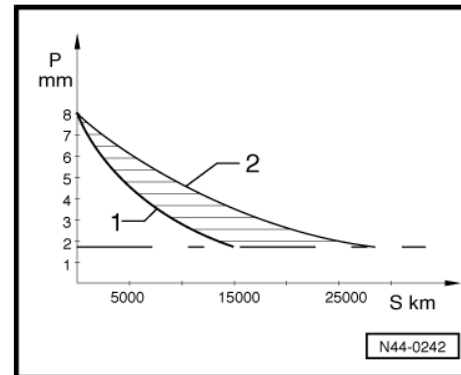

Diagram 1:

Tread depth versus tyre life for vehicles with front-wheel drive and V-rated tyres

P - Tread depth

S - Kilometres driven

1 - Front axle

2 - Rear axle

Protected by copyright. Copying for private or commercial purposes, in part or in whole, is not permitted without the express authorisation of ŠKODA AUTO A. S. ŠKODA AUTO A. S. does not guarantee or accept any liability with respect to the correctness of information in this document. Copyright by ŠKODA AUTO A. S. ©

Diagram 2:

Tread depth over tyre service life for vehicles with four-wheel drive and V-rated tyres

P - Tread depth

S - Kilometres driven

1 - Front axle

2 - Rear axle

Diagrams 1 and 2 show that the tread on a new tyre wears faster than that on a heavily used tyre. As the wear curve is not linear, it is not possible to estimate the tyre service life on the basis of wear after the first 5,000 km.

On front-wheel drive vehicles, the front tyres not only have to transmit the steering and driving forces, but also the greater part of the lateral and braking forces. This causes the front tyres on front-wheel drive vehicles to wear much faster than the rear tyres. Even tyre wear can be achieved by rotating (interchanging) the front and rear tyres on a regular basis ⇒ [page 71](#) .

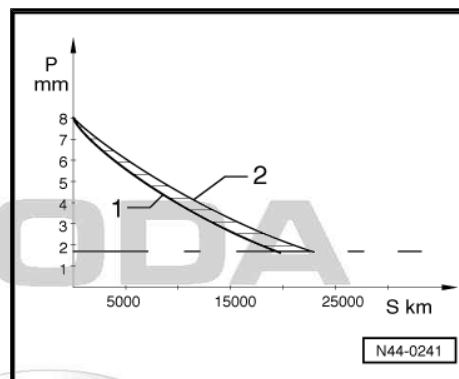

4.7 Evenly worn tyres

The requirements to be met by tyres are increasing continuously:

- ◆ greater vehicle weight
- ◆ high speeds
- ◆ high level of vehicle safety

Greater loads on the tyre will, of course, lead to an increase in tyre wear.

Protected by copyright. Copying for private or commercial purposes, in part or in whole, is not permitted unless authorised by ŠKODA AUTO A. S. ŠKODA AUTO A. S. does not guarantee or accept any liability for the accuracy of information in this document. Copyright by ŠKODA AUTO A. S.

Driving style has a critical effect on tyre wear. For this reason, customer claims regarding tyre wear on evenly worn tyres are not covered by the warranty.

The effective service life of a tyre can be determined only when the remaining tread depth has reached 2 mm, see diagram ⇒ [page 19](#) .



4.8 Measuring tread depth

Special tools and workshop equipment required

- ◆ Test pin -40139A-

Note

- ◆ *The tread depth is measured in the main tread channels.*
- ◆ *Do not measure at the TWIs (Tread Wear Indicators).*

The position of the TWIs can be seen at various points on the shoulder of the tyre => [Item 2 \(page 3\)](#) .

A „Δ“ or the “manufacturer’s logo” may appear in the place of “TWI”.

The bars of the TWI have a height of 1.6 mm. This is the minimum tread depth required by Czech law. Different values may apply in other countries.



WARNING

The TWIs must not be included in the measurement. Tread depth should always be measured at the deepest point of the tread channel.

ŠKODA

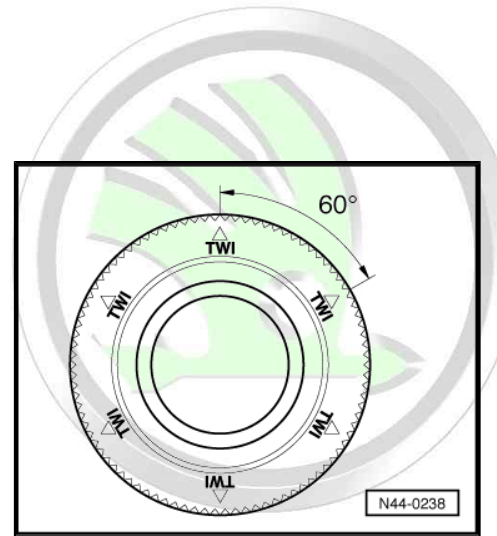

Protected by copyright. Copying for private or commercial purposes, in part or in whole, is not permitted unless authorised by ŠKODA AUTO A. S. ŠKODA AUTO A. S. does not guarantee or accept any liability with respect to the correctness of information in this document. Copyright by ŠKODA AUTO A. S.



Different values may apply in other countries.

A - TWIs in the main tread channels

B - Main tread channels with TWIs -arrows-

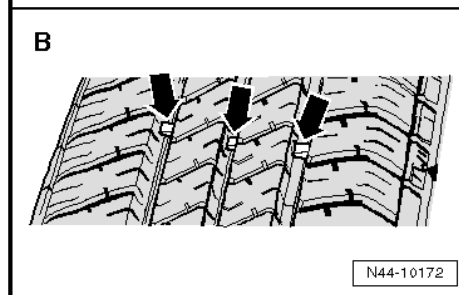
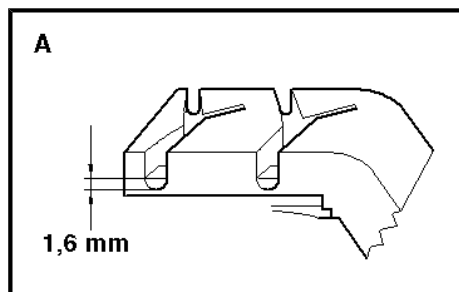

- Position the test pen -40139A- on the bead of the outer tread of the tyre -arrow-.

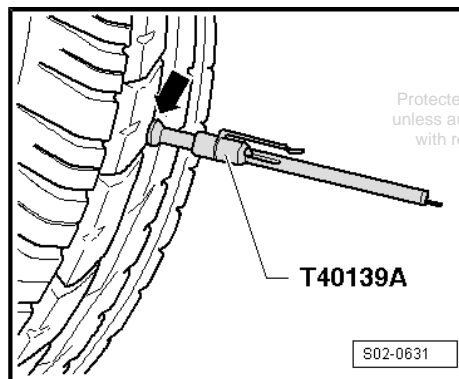

ŠKODA



Protected by copyright. Copying for private or commercial purposes, in part or in whole, is not permitted unless authorised by ŠKODA AUTO A. S. ŠKODA AUTO A. S. does not guarantee or accept any liability with respect to the correctness of information in this document. Copyright by ŠKODA AUTO A. S. ©



- Move the grinder -3- in such a way that the measuring pin of the test pen -4- fully rests against the inner tread of the tyre.
- Remove the test pen and read off the tread depth of the tyre in (mm) on the scale -2-(with tyre symbol) of the test pen.

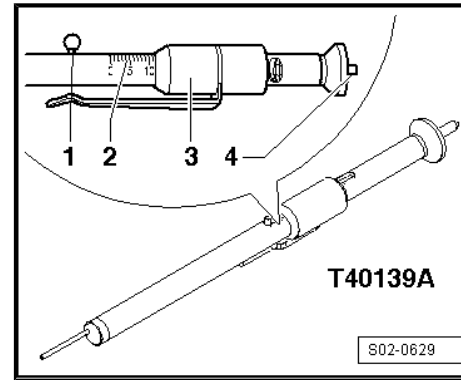

ŠKODA

4.9 Unilateral wear

This is often caused by driving style, but can be the result of incorrect wheel alignment.

Increased unilateral wear

Unilateral wear, usually in conjunction with signs of scuffing on the ribs of the tread and in the fine grooves, always occurs when the tyres have been allowed to roll with an extreme tyre slip angle, causing them to »rub« on the road surface.

Driving fast on a stretch of road with lots of curves will cause increased wear, in particular on the outer shoulder.

A rounded outer shoulder on the tyre in conjunction with a particularly high degree of wear on the outer tread blocks indicates fast cornering. This wear pattern is influenced by driving style.

To optimise handling, the suspension is set to specified toe-in and camber values. Increased unilateral wear can be expected if tyres are allowed to roll under conditions which differ from those specified.

Unilateral wear is especially likely if the toe and camber have not been set correctly; moreover, there is a greater risk of diagonal washout.





Toe-out

Distance between front of wheels -A- is greater than distance between rear of wheels -B- (-C- direction of travel).

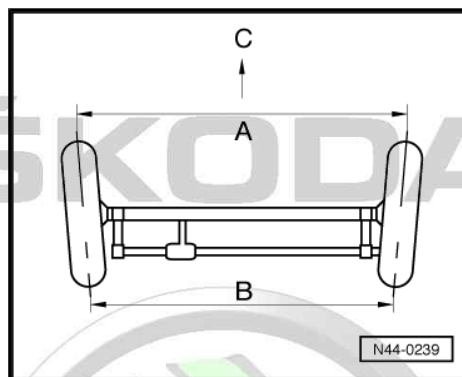

Protected by copyright. Copying for private or commercial purposes, in part or in whole, is not permitted unless authorised by ŠKODA AUTO A. S. ŠKODA AUTO A. S. does not guarantee or accept any liability with respect to the correctness of information in this document. Copyright by ŠKODA AUTO A. S. ©



Toe-in

Distance between front of wheels -A- is less than distance between rear of wheels -B- (-C- direction of travel).

To prevent unilateral wear, care must be taken to ensure that the wheel is set within the tolerance specified by the vehicle manufacturer. The most frequent deviation of the wheel alignment is caused by external influences, for example hard contact with the kerbstone when parking.

By measuring the axle geometry, you can check whether the wheel alignment is within the specified tolerances or whether it has to be corrected. Axle alignment ⇒ Axles, steering; Rep. gr. 44 .

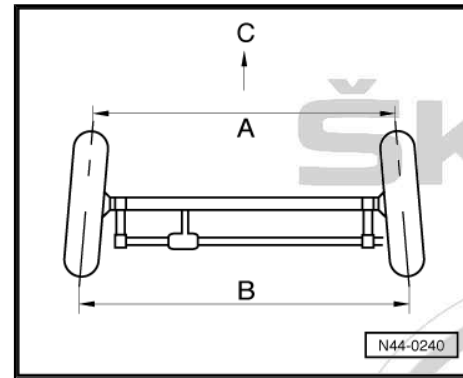

Modifications made to the suspension

Using “suspension-lowering kits” and/or alloy wheels that have not been recommended by Škoda may result in altered wheel positions which deviate from the specified alignment.

Even if the axle geometry is correct with the vehicle stationary during wheel alignment, the changed vehicle height and wheel positions can cause the wheel suspension to move differently during operation.

Uneven wear is then unavoidable.

The way to prevent unilateral wear is to ensure the wheel alignment is correct on one hand and on the other hand to make sure the vehicle is used only for its intended purpose.

Regular servicing of the vehicle and tyres helps to prevent tyre wear. The following should be noted in particular with regards to this:

- ◆ The prescribed tyre inflation pressures must be adhered to.
- ◆ Different wear on the front and rear axle depending on the driving style is unavoidable. This condition can be compensated for by rotating the wheels from front to rear. This ensures that all tyres can wear down equally, meaning that a completely new set of tyres can be fitted. This prevents differences between the tread depths of the tyres on each axle, which can have negative effects on road holding.

Protected by copyright. Copying for private or commercial purposes, in part or in whole, is not permitted unless authorised by ŠKODA AUTO A. S. ŠKODA AUTO A. S. does not guarantee or accept any liability with respect to the correctness of information in this document. Copyright by ŠKODA AUTO A. S. ©



- ◆ Saw tooth formation is a normal wear pattern, particularly if the driving style is very careful. This can lead to increased rolling noise, which generally becomes better as the tread depth decreases. In the event of light saw tooth formation or if saw tooth formation is just starting, exchanging the wheels between axles is normally sufficient. If saw tooth formation is very pronounced, the wheels have to be changed so that their direction of rotation is reversed.
- ◆ Some tread patterns may create an impression of premature wear: If winter tyre sipes or channels in the tread are worn down, only compact profile blocks without patterns remain, thus giving the impression of a worn tyre. In this case, the remaining tread depth must be measured in each groove. If this is at or below the minimum tread depth, the tyre can continue to be used without restrictions.

4.10 Outside shoulder wear

The way to prevent unilateral wear is to ensure the wheel alignment is correct on one hand and on the other hand to make sure the vehicle is used only for its intended purpose.

Regular servicing of the vehicle and tyres helps to prevent tyre wear. The following should be noted in particular with regards to this:

- ◆ The prescribed tyre inflation pressures must be adhered to.
- ◆ Different wear on the front and rear axle depending on the driving style is unavoidable. This condition can be compensated for by rotating the wheels from front to rear. This ensures that all tyres can wear down equally, meaning that a completely new set of tyres can be fitted. This prevents differences between the tread depths of the tyres on each axle, which can have negative effects on road holding.
- ◆ Saw tooth formation is a normal wear pattern, particularly if the driving style is very careful. This can lead to increased rolling noise, which generally becomes better as the tread depth decreases. In the event of light saw tooth formation or if saw tooth formation is just starting, exchanging the wheels between axles is normally sufficient. If saw tooth formation is very pronounced, the wheels have to be changed so that their direction of rotation is reversed.



- ◆ Some tread patterns may create an impression of premature wear: If winter tyre sipes or channels in the tread are worn down, only compact profile blocks without patterns remain, thus giving the impression of a worn tyre. In this case, the remaining tread depth must be measured in each groove. If this is at or below the minimum tread depth, the tyre can continue to be used without restrictions.

4.11 Wear in middle of tyre

This wear pattern is found on the driven wheels of high-performance vehicles that are frequently driven long distances at high speeds.

At high speeds, centrifugal forces cause the tyre diameter to increase more in the middle of the tread than it does at the shoulder. This causes drive forces to be transferred to the road surface from the centre section of the tread. This is reflected in the wear pattern.

Effects of this kind can be especially pronounced on wide tyres.

It is not possible to counter this wear pattern by reducing the tyre pressure.



WARNING

For safety reasons, the tyre pressure must not under any circumstances be reduced below the specified tyre pressure.

A more or less even tread wear pattern can be achieved by interchanging the tyres on the driven wheels and non-driven wheels in good time.

ŠKODA



Protected by copyright. Copying for private or commercial purposes, in part or in whole, is not permitted unless authorised by ŠKODA AUTO A. S. ŠKODA AUTO A. S. does not guarantee or accept any liability with respect to the correctness of information in this document. Copyright by ŠKODA AUTO A. S.®



Increased tread wear

The typical tread wear pattern of tyres run on the driven wheels of a high-performance vehicle.

The increased wear in the centre section of the tread results from the extra loading associated with centrifugal forces within the tyre and the transmission of drive forces.

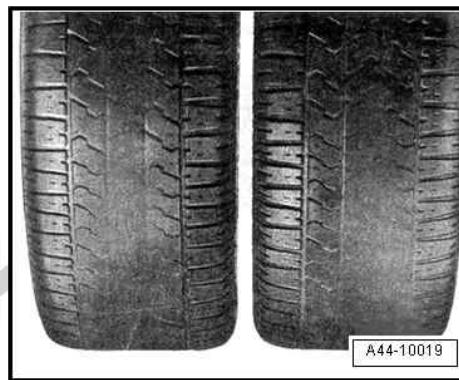

Protected by copyright. Copying for private or commercial purposes, in part or in whole, is not permitted unless authorised by ŠKODA AUTO A. S. ŠKODA AUTO A. S. does not guarantee or accept any liability with respect to the correctness of information in this document. Copyright by ŠKODA AUTO A. S. ©



4.12 Diagonal washout

Diagonal washout on a tyre

Diagonal washout runs at an angle of approx. 45° to the direction of rotation.

It usually occurs at one point only, but can also occur at several points around the circumference of the tyre.

Washout occurs almost exclusively on the tyres on the non-driven wheels, in particular at the rear left. Washout occurs very often on some models, while it poses no problem at all on other models. The effect is intensified by high toe-in values. Toe-in values in the region of the lower tolerance limits of the specified alignment values improve the wear pattern.

The most pronounced diagonal washout is often found in the area where the tyre components are joined.

Wheels with positive toe-in roll with a slip angle even straight ahead. This leads to a diagonal stress in the contact patch or footprint on the tyre/road surface.

This wear pattern is intensified when tyre pressure is too low. To avoid such tread wear patterns, the toe-in values of the two rear wheels should be identical and the specified tyre pressures observed.

If you detect washout, you should fit the wheels on the driven axle, assuming the washout is identified at an early stage. Deeper washout cannot be repaired.

Faulty adjustment

If a customer complains of “diagonal wear spots”, the toe adjustment must be examined. If toe-in is correct, the cause of the diagonal washout is very probably the tyre itself.

Tyres with diagonal washout caused by incorrectly set axle geometry at the wheels are not covered by warranty.

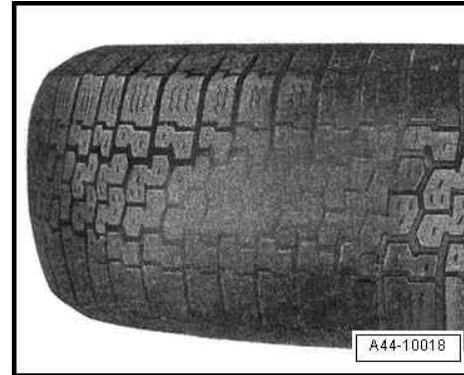



5 Tyre noise

General notes on tyre noise ⇒ [page 30](#)

Saw-tooth wear ⇒ [page 31](#)

Flat spots ⇒ [page 33](#)

5.1 General notes on tyre noise

Tyre noise that can be heard by the human ear is caused by vibrations which are transmitted by the air.

The cause of the noise is largely dependent on the combination of the road surface and tyres.

The structure and material of the road surface will greatly affect tyre noise. For example, the noise level on a wet road is much higher than on a dry road.

The pattern of the tyre tread also has a significant influence on tyre noise. Tyres with transverse grooves at an angle of 90° generate more noise than tyres with grooves running diagonally.

Small tread blocks are unstable. Their highly pronounced deformation agitates the air as the tyres roll. This creates the air vibrations that cause tyre noise.

Wider tyres are louder. They need more tread channels to displace water. When they are rolling, these tread channels displace the air, also creating air vibrations.

Further effects that also influence tyre noise:

- ◆ „Tyre vibration“ is the principal cause of tyre noise. It is caused by the columns of air in the tread channels being agitated.
- ◆ „Air pumping“ is the compression and expansion of the air caused by the deformation of the tread blocks as the tyre contact patch moves along the road surface.

Useful information regarding tyre noise

Tyre noise is determined primarily by the tyres and the road surface.

Reproduction for commercial purposes, in part or in whole, is not permitted unless authorised by ŠKODA AUTO A. S. ŠKODA AUTO A. S. does not guarantee or accept any liability for the content of this document. ŠKODA AUTO A. S. ©



The roughness, structure and material of the road surface influence tyre noise.

The widths of the tyre and the rim, among other things, influence tyre noise. Due to their larger contact area, wider tyres will cause more tyre noise than narrow tyres, as more air has to be displaced and more „mass“ is agitated to create vibrations.

A wider wheel rim will also cause a tyre to have a wider contact patch. The effect on tyre noise is thus very similar to that of a wider tyre. Moreover, the damping characteristics of the tyre may also be adversely affected by the wider wheel rim.

On vehicles with a front-mounted engine, tyre noise is more perceptible at the rear of the vehicle, as wind and engine noises are not as loud there.

5.2 Saw-tooth wear

Saw-tooth wear is a stepped wear pattern on the individual tread blocks that can cause increased tyre noise. The saw tooth is caused by uneven deformation of the tread blocks in the tyre's contact patch. Saw-tooth wear is more pronounced on non-driven wheels than on driven wheels.

Protected by copyright. Copying for private or commercial purposes, in part or in whole, is not permitted unless authorised by ŠKODA AUTO A. S. ŠKODA AUTO A. S. does not guarantee or accept any liability with respect to the correctness of information in this document. Copyright by ŠKODA AUTO A. S. ©



New tyres are more susceptible to saw-tooth wear because of the greater elasticity of the high tread blocks. As the tread depth decreases, the tread blocks become more rigid and the tendency to wear in a saw-tooth pattern decreases.

Appearance of saw tooth

A - Tread block of a new tyre; seen in direction of motion -arrow 1-, tread blocks are equally high in front and back.

B - Development of saw teeth; seen in the direction of rotation -arrow 1-, tread blocks are higher in front -arrow 2- than in back.

C - Seen in the direction of rotation -arrow 1-, tread blocks show greater wear in the front section of the „saw tooth” -arrow 3-.

Pronounced saw-tooth wear can lead to customers complaining about tyre noise.

Pronounced saw-tooth wear occurs under the following conditions:

- ◆ toe values are too high
- ◆ tyre pressures are incorrect
- ◆ tread is coarse and open
- ◆ tyres are fitted on the non-driven axle
- ◆ very fast cornering

Non-directional tyres

In the event of saw-tooth wear, the direction of rotation of the tyre must be reversed. If saw-tooth wear is especially pronounced and tyre noise has increased, interchange the tyres diagonally.

On front-wheel-drive vehicles, this effect is intensified by the greater wear on the front axle.

Tyre noise will be somewhat louder immediately after the tyres have been interchanged but will return to a normal level after about 500...1,000 km have been driven.

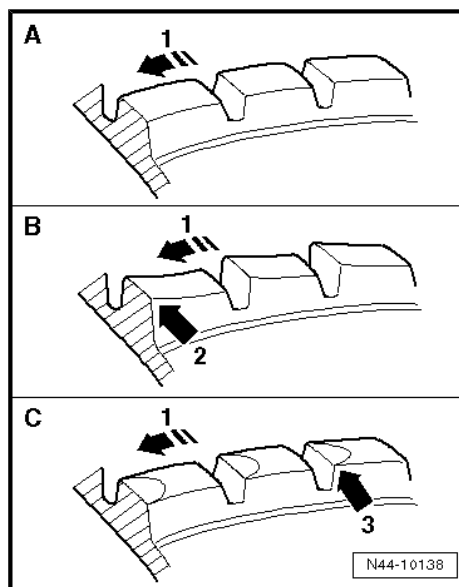

ŠKODA



Protected by copyright. Copying for private or commercial purposes, in part or in whole, is not permitted unless authorised by ŠKODA AUTO A. S. ŠKODA AUTO A. S. does not guarantee or accept any liability with respect to the correctness of information in this document. Copyright by ŠKODA AUTO A. S. ©



Directional tyres

In the event of increased saw-tooth wear on the rear tyres (in particular on front-wheel drive vehicles) interchange the front and rear tyres. In the event of increased saw-tooth wear on the outer edges of the tyres on one axle, turn both tyres around on their rims. The left-hand wheel must then be fitted on the right side of the vehicle and the right-hand wheel on the left side.

5.3 Flat spots

Flat spots can result from an extreme brake application which causes the wheels to lock, so that the rubber is worn off at the contact patch between the tread and the road surface.

As the tyres slide over the road surface, friction generates heat, which also reduces the wear resistance of the tread material.

Not even a highly wear-resistant tread compound can prevent the flat spots caused by violent braking.

Even ABS-controlled brake systems cannot prevent brief locking of the wheels, and thus, minor flat spots.

The degree of such wear depends largely on the vehicle speed, the road surface and the load placed on the wheel. The following examples should make this clear.

If a vehicle is braked to a standstill on a dry surface with the wheels locked, the amount of rubber worn from the tyre will cover an area the size of a postcard and will have a thickness of:

- ◆ up to 2,0 mm from a speed of 57 km/h (23,8 m braking distance)
- ◆ up to 3,3 mm from a speed of 75 km/h (41,8 m braking distance)
- ◆ up to 4.8 mm from a speed of 92 km/h (71.6 m braking distance)

ŠKODA



Protected by copyright. Copying for private or commercial purposes, in part or in whole, is not permitted unless authorised by ŠKODA AUTO A. S. ŠKODA AUTO A. S. does not guarantee or accept any liability with respect to the correctness of information in this document. Copyright by ŠKODA AUTO A. S. ©



Flat spots in tread

Tyres with such damage must no longer be used and must be renewed.

ŠKODA

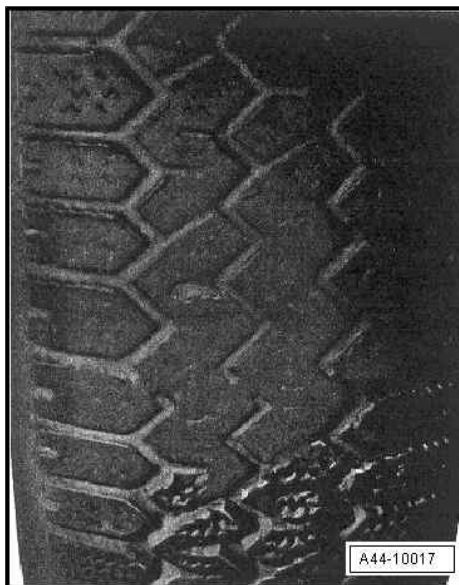

Protected by copyright. Copying for private or commercial purposes, in part or in whole, is not permitted unless authorised by ŠKODA AUTO A. S. ŠKODA AUTO A. S. does not guarantee or accept any liability with respect to the correctness of information in this document. Copyright by ŠKODA AUTO A. S. ©



6 Rough running due to wheels/tyres - causes

Causes of rough running ⇒ [page 35](#)

Balancing ⇒ [page 36](#)

Conducting a road test before balancing wheels ⇒ [page 36](#)

Balancing wheel on stationary wheel balancer ⇒ [page 37](#)

Finish balancer ⇒ [page 38](#)

Radial and lateral runout on wheels and tyres ⇒ [page 40](#)

Checking radial and lateral runout on wheels/tyres with tyre gauge ⇒ [page 40](#)

Checking radial and lateral runout on wheel rim ⇒ [page 41](#)

Match mounting ⇒ [page 42](#)

Flat spots on tyres ⇒ [page 44](#)

6.1 Causes of rough running

Rough running can have a number of different causes. It can also be caused by tyre wear. Tyre wear caused by driving is not always evenly spread across the entire running surface of the tyre. This causes slight imbalances which affect the smooth running of a wheel which was previously exactly balanced.

Minor imbalances will not be felt at the steering wheel, but that does not mean that they are not there. They increase wear on the tyre and thus reduce the tyre service life.

Recommendation

To ensure

- optimal safety
- smoothest possible running and
- even wear

throughout a tyre's service life, we recommend having the wheels and tyres balanced at least twice during the tyre's service life.

ŠKODA



Protected by copyright. Copying for private or commercial purposes, in part or in whole, is not permitted unless authorised by ŠKODA AUTO A. S. ŠKODA AUTO A. S. does not guarantee or accept any liability with respect to the correctness of information in this document. Copyright by ŠKODA AUTO A. S. ©



6.2 Balancing

The following conditions must be met before balancing wheels.

- Tyre pressure must be OK.
- The tyre tread must not show one-sided wear and should be at least 4 mm deep.
- The tyre must not show any signs of damage, for example cuts, piercing, foreign bodies, etc.
- The wheel suspension, steering and steering linkage, including the shock absorbers, must be in perfect condition.
- A road test was conducted.

6.3 Conducting a road test before balancing wheels

If a customer brings a vehicle to the workshop complaining about "vibration", a road test is essential prior to balancing the wheels.

- ◆ This will give you information about the nature of the rough running.
- ◆ You will be able to determine the speed range in which rough running occurs.
- Raise the vehicle on a lifting platform immediately after the road test.
- Mark the tyre position.

Tyre position	Identification
Front left tyre	FL
Front right tyre	FR
Rear left tyre	RL
Rear right tyre	RR

- Remove wheels.
- Balance wheels.



6.4 Balancing wheel on stationary wheel balancer

Clamp wheel into wheel balancing machine



Note

Dabei auf Sauberkeit achten. Only then a satisfactory result can be achieved!

Dirt and rust in the area of the contact surfaces and centre of the wheel distort the result.

- Clean the contact surface, the centering and the wheel disc before the wheel is mounted on the balancer!
- Attach the wheel (together with tyre) to the wheel balancing machine.

Procedure for balancing wheels and tyres

- Let the wheel/tyre rotate on the balancer.
- Check the course of the characteristic curves on the side walls of the tyre in the area of the rim flange.
- Check the tyre tread image on a rotating wheel/tyre.



Note

If one-sided wear, flat spots from braking or severely washed out spots are apparent, balancing cannot achieve smooth running. In this case, the tyre must be replaced.

- Check the wheel/tyre for true running. If the wheel and tyre do not run true although there are no flat spots, radial or lateral runout may be the cause.
- Check the wheel with tyre for radial or lateral runout.
- If radial and lateral runout are within the specified tolerance, balance the wheel and tyre.

ŠKODA



Protected by copyright. Copying for private or commercial purposes, in part or in whole, is not permitted unless authorised by ŠKODA AUTO A. S. ŠKODA AUTO A. S. does not guarantee or accept any liability with respect to the correctness of information in this document. Copyright by ŠKODA AUTO A. S.®

**Note**

- ◆ *More than 60 grams of weight per tyre should not be used.*
- ◆ *If more weight is required, you may be able to achieve smoother running by "matching" the tyre and rim ⇒ [page 42](#) .*
- ◆ *The wheel balancer display should indicate 0 gram.*
- Bolt the wheel onto the vehicle.
- First, hand-tighten the lowest wheel bolt to about 30 Nm.
- Then tighten the remaining wheel bolts in diagonal sequence to approx. 30 Nm. This process centres the wheel on the hub.
- Place vehicle onto its wheels.
- Now tighten the wheel bolts with the torque wrench to the specified torque in diagonal sequence.
- After balancing the wheels/tyres, carry out a road test.

If you detect vibration during the road test, it may be due to tolerance in the wheel centring.

In unfavourable circumstances, the component tolerances of wheels and hubs could cumulate. This too can lead to vibration. This can be alleviated using a finish balancer ⇒ [page 38](#) .

6.5 Finish balancer

**Note**

- ◆ *Before working with a finish balancer , the mechanic needs to have been instructed by the manufacturer of the balancer.*
- ◆ *To balance the wheels, set the wheels of the driven axle on the sensor platforms, i.e. the front wheels for front-wheel drive models.*

If you determine a residual imbalance greater than 20 grams when balancing the wheels, you should rotate the mounting position of the wheel on the hub.

ŠKODA





- Mark the point at which the imbalance is indicated.
- Then, unbolt the wheel and rotate its position on the hub so that the marking points downwards.

i Note

The hub must not rotate during this procedure.

- First, hand-tighten the lowest wheel bolt to about 30 Nm.
- Then tighten the remaining wheel bolts in diagonal sequence to approx. 30 Nm. This process centres the wheel correctly on the hub.
- Check whether the imbalance is less than 20 grams using the finish balancer.

i Note

The imbalance should always be less than 20 grams before you change the balance weight.

- Loosen the wheel bolts again if necessary.
- Rotate wheel again by 1 or 2 wheel bolt holes in relation to wheel hub.
- Tighten wheels using the method described above.

i Note

Do not try to reduce the imbalance using balancing weights until the imbalance is less than 20 grams.

- Balance wheels if imbalance is less than 5 grams.
- Tighten wheel bolts to specified torque if you have not already done so.

ŠKODA



Protected by copyright. Copying for private or commercial purposes, in part or in whole, is not permitted unless authorised by ŠKODA AUTO A. S. ŠKODA AUTO A. S. does not guarantee or accept any liability with respect to the correctness of information in this document. Copyright by ŠKODA AUTO A. S. ©

**WARNING**

Always tighten wheel bolts to specified tightening torque using a torque wrench!

6.6 Radial and lateral runout on wheels and tyres

Radial and lateral runout occur when the wheel and tyre do not run absolutely true.

For technical reasons, 100% true running is not possible.

Therefore, the manufacturers of these components allow a precisely determined tolerance.

Mounting the tyre in an unfavourable position on the wheel can cause the maximum allowed tolerance for wheel with tyre to be exceeded.

The table shows the maximum permissible tolerances for a wheel with mounted tyre.

Tolerances for radial and lateral runout of rims with tyres

Rim with tyre	Radial runout (mm)	Lateral runout (mm)
Passenger cars	0,9	1,1 (1.3 mm in vicinity of lettering)

ŠKODA

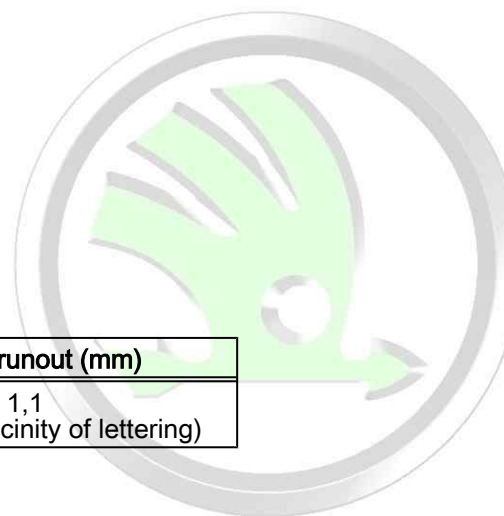

Protected by copyright. Copying for private or commercial purposes, in part or in whole, is not permitted unless authorised by ŠKODA AUTO A. S. ŠKODA AUTO A. S. does not guarantee or accept any liability with respect to the correctness of information in this document. Copyright by ŠKODA AUTO A. S. ©

6.7 Checking radial and lateral runout on wheels/tyres with tyre gauge

Checking lateral runout

- Preload tyre gauge approx. 2 mm.



- Fit tyre gauge to side wall of tyre.
- Turn wheel slowly.
- Make a note of the smallest and largest deflection of the indicator needle.

i Note

If the difference is greater than 1.3 mm, the lateral runout is too great.

In this case, the lateral runout can be reduced by match mounting the tyre => [page 42](#) .

Extreme values on the tyre gauge due to small irregularities in the rubber may be disregarded.

Checking radial runout

- Preload tyre gauge approx. 2 mm.
- Fit tyre gauge to running surface of tyre.
- Turn wheel slowly.
- Make a note of the smallest and largest deflection of the indicator needle.

i Note

If the difference is greater than 1 mm, the radial runout is too great.

In this case, the radial runout can be reduced by match mounting the tyre => [page 42](#) .

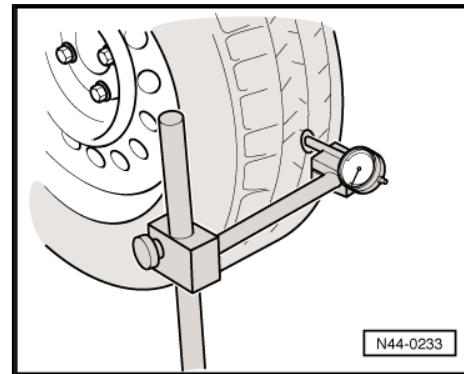
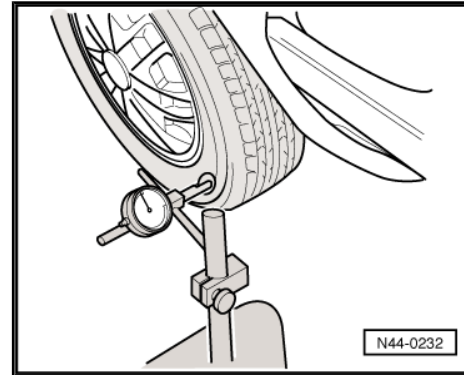

Protected by copyright. Copying for private or commercial purposes, in part or in whole, is not permitted unless expressly permitted by SKODA AUTO A. S. SKODA AUTO A. S. does not guarantee or accept any liability with respect to the information in this document. Copyright by SKODA AUTO A. S.

6.8 Checking radial and lateral runout on wheel rim

- Attach the rim to the wheel balancing machine .
- Preload tyre gauge approx. 2 mm.



- Turn rim slowly.
- Make a note of the smallest and largest deflection of the indicator needle.

S - Lateral runout

H - Radial runout

- Compare the measured values with the specifications in the table => [page 42](#) .

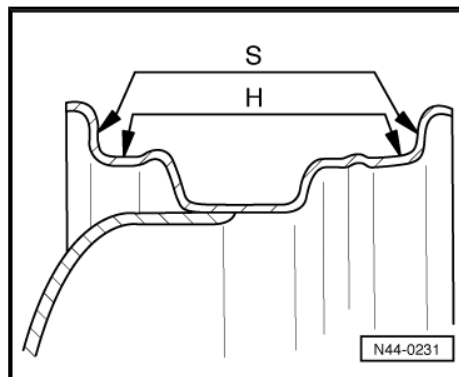

ŠKODA



Note

Extreme values on the tyre gauge due to small irregularities may be disregarded.

Specified values for radial and lateral runout on wheel rim

	Rim	Radial runout (mm)	Lateral runout (mm)
Passenger cars	Steel wheel	0,5	0,5
	Light-alloy wheel	0,5	0,8



Note

If the measured value exceeds the specification, acceptably smooth running cannot be attained.



Protected by copyright. Copying for private or commercial purposes, in part or in whole, is not permitted unless authorised by ŠKODA AUTO A. S. ŠKODA AUTO A. S. does not guarantee or accept any liability with respect to the correctness of information in this document. Copyright by ŠKODA AUTO A. S.

6.9 Match mounting

General notes

When radial or lateral runout of the rim and tyre coincide, the imbalance of the wheel is amplified by the tyre.

For technical reasons, 100% true running is not possible.



Before match mounting the used wheels which are fitted on the vehicle, run the tyres warm. Thus any existing flat spots are removed.

Procedure for match mounting

- Let air out of tyre.
- Press tyre beads off wheel rim flanges.
- Apply tyre assembly paste all round the tyre beads.
- Rotate tyre by 180° in relation to rim.
- Pump up tyre to approx. 4 bar.
- Attach the wheel (together with tyre) to the wheel balancing machine.
- Check wheel for true running and for radial and lateral runout.

ŠKODA

Note

- ◆ *If the specified values for radial and lateral runout are not exceeded, the wheel can be balanced to 0 gram. Specified value => [page 40](#).*
- ◆ *If the radial and lateral runout are not within the specified values, the tyre must be rotated again.*
- Let air out and press tyre beads off the wheel rim flanges.
- Rotate tyre by 90° in relation to rim (quarter of a turn).
- Pump up tyre again to 4 bar and check true running.



Note

- ◆ *If the specified values for radial and lateral runout are not exceeded, the wheel can be balanced to 0 gram.*
- ◆ *If the radial and lateral runout are never within the specified values, the tyre must be rotated again.*
- Let air out and press tyre beads off the wheel rim flanges.

Copyright. Copying for private or commercial purposes, in part or in whole, is not permitted unless authorised by ŠKODA AUTO A. S. ŠKODA AUTO A. S. does not guarantee or accept any liability with respect to the correctness of information in this document. Copyright by ŠKODA AUTO A. S. ©



- Rotate tyre by 180° in relation to rim (quarter of a turn).
- Pump up tyre again to 4 bar and check true running.

If the radial and/or lateral runout are still not within the specified values, check the rim for radial and/or lateral runout ⇒ [page 41](#) .

If the measured values for radial and lateral runout of the rim are within the specified values, the tyre has an impermissibly high radial or lateral runout. In this case, the tyre must be renewed.

**Note**

- ◆ *After fitting the tyres there will be fitting lubricant between the tyres and the rim flanges.*
- ◆ *You should therefore avoid severe braking and acceleration manoeuvres for the first 100...200 km driven. The tyres might otherwise twist on the rim.*

6.10 Flat spots on tyres

What is a flat spot?

The terms flat area and flats are also used for the term flat spot.

Flat spots caused by storage or handling also cause vibration in the same way as incorrectly balanced wheels do. Correct identification of each flat spot on the running surface is important.

Flat spots caused by storage or handling cannot be balanced and they can reoccur at any time due to various circumstances. Flat spots caused by storage or handling can be eliminated without complicated special tools. Provided it is not a flat spot caused by full braking ⇒ [page 33](#) .

**Note**

Flat spots caused by hard braking cannot be repaired. Such tyres must be renewed.



Reasons for flat spots caused by storage or handling:

- ◆ The vehicle has been left standing in one place without being moved for several weeks.
- ◆ The tyre pressure is too low.
- ◆ The vehicle was placed in a paint shop drying booth after being painted.
- ◆ The tyres of the vehicle were warm when it was parked in a cool garage. In this case, a standing flat spot may even occur overnight.

Eliminating flat spots caused by storage or handling

- ◆ Flat spots caused by storage or handling cannot be eliminated from the tyre using workshop equipment.
- ◆ Flat spots caused by storage or handling can be removed only by running the tyres warm.
- ◆ The method described below is not recommended in cold and wintry weather.

Requirements and conditions:

- Check and correct tyre pressure.
- Traffic and road conditions permitting, drive a 20...30 kilometre stretch at a speed of 120...130 km/h when performing the road test.



WARNING

Do not endanger anyone when performing the road test.

Observe the highway code and speed limitations in force when performing the road test.

- Raise the vehicle immediately after the road test.
- Unbolt wheels from vehicle.
- Balancing wheels on stationary wheel balancer ⇒ [page 37](#) .

ŠKODA



Protected by copyright. Copying for private or commercial purposes, in part or in whole, is not permitted unless authorised by ŠKODA AUTO A. S. ŠKODA AUTO A. S. does not guarantee or accept any liability with respect to the correctness of information in this document. Copyright by ŠKODA AUTO A. S. ©



7 Vehicle pulls to one side

General points ⇒ [page 46](#)

Conicity ⇒ [page 47](#)

Remedies when vehicle pulls to one side ⇒ [page 49](#)

Strategic rotation of wheels for non-directional tyres
⇒ [page 50](#)

Strategic rotation of wheels having unidirectional tyres
⇒ [page 52](#)

7.1 General notes

Perform a road test to determine whether a vehicle is pulling to one side and if so, which side. If the vehicle pulls to one side ⇒ [page 49](#) .

When wheel alignment is checked, include the wheel alignment test results in tyre complaint report.

Manufacturer's tolerances can lead to a slight amount of taper (asymmetry) in the tyre carcass. The rolling tyre then develops a lateral force which acts directly on the wheel suspension, leading to self-steering of the vehicle. Strategic rotation of the wheels can balance out this self-steering behaviour.

ŠKODA



Protected by copyright. Copying for private or commercial purposes, in part or in whole, is not permitted unless authorised by ŠKODA AUTO A. S. ŠKODA AUTO A. S. does not guarantee or accept any liability with respect to the correctness of information in this document. Copyright by ŠKODA AUTO A. S. ©



7.2 Conicity

Conicity is caused by a slight offset of the tread and/or the belt (amounting to a few tenths of a millimetre) relative to the geometric centre of the tyre. Taper is not visible and cannot be measured with equipment available in the workshop.

Parts of a tyre

1 - Bead

2 - Shoulder

3 - Tread

4 - Steel cord belt

A - Geometrical centre of tyre

B - Actual centre of belt. It can be offset to inside or outside.

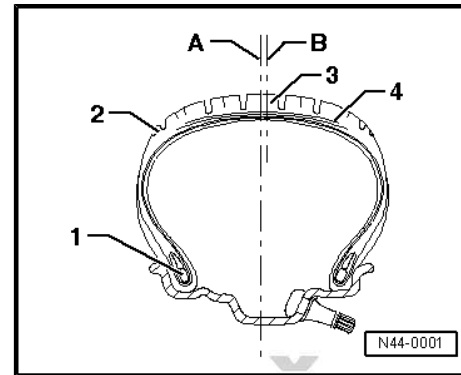

ŠKODA



Protected by copyright. Copying for private or commercial purposes, in part or in whole, is not permitted unless authorised by ŠKODA AUTO A. S. ŠKODA AUTO A. S. does not guarantee or accept any liability with respect to the correctness of information in this document. Copyright by ŠKODA AUTO A. S. ©



Exaggerated for clarity.

1 - Offset of belt and tread

F1 - Unequal vertical wheel forces

F2 - Unequal vertical wheel forces

Fk - Conicity force

The offset produces differences in stiffness at the inner and outer shoulders of the tyre, resulting in differing vertical wheel forces. Consequently the belt or tread will not be pressed onto the road surface with the same force (F1, F2). A conical, or tapered, shape develops. The resulting force (conicity force Fk) can, depending on the speed, become so great that the vehicle then pulls to one side.

If the force Fk on one wheel of the axle is, for example, 50 Newton, and also 50 Newton on the other wheel, and both forces are exerted in the same direction, the forces are cumulated. Reversing a tyre on the rim can compensate for the lateral pull because the forces then act in opposite directions.

Because the direction in which the force of taper is exerted is not visible, only road tests and strategic rotation of wheels and tyres can establish which tyres cause the pulling.

The tyre consists of numerous components and materials which are vulcanised to form a single part at the end of a complicated manufacturing process. The result is differing production tolerances which make themselves noticeable through more or less strong lateral forces (conicity forces). These forces can also occur in new tyres.

Pulling to one side on front axle

Pulling to one side can be caused by the chassis. However, experience shows that in 90% of all complaints, the tyres cause pulling to one side.

Pulling to one side during normal driving

On a straight, level road surface, the vehicle wants to pull to one side at a constant speed or with moderate acceleration. Force can be felt at the steering wheel.

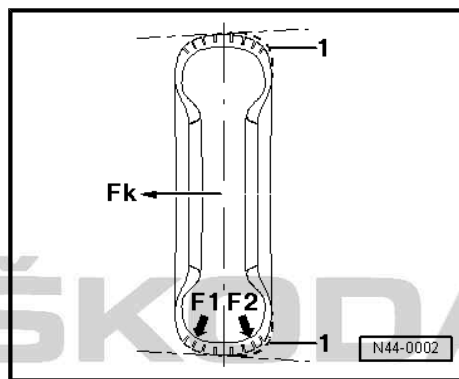

Protected by copyright. Copying for private or commercial purposes, in part or in whole, is not permitted unless authorised by ŠKODA AUTO A. S. ŠKODA AUTO A. S. does not guarantee or accept any liability with respect to the correctness of information in this document. Copyright by ŠKODA AUTO A. S. ©



Pulling to one side during fast acceleration

Pulling to one side during fast acceleration is, in part, due to the basic design of vehicles with front wheel drive. Different friction levels at the left and right wheels or possible irregularities in the road surface (potholes) and consequently varying road adhesion have a substantial influence on the handling characteristics. This does not constitute a complaint which is covered by the warranty.

7.3 Remedies when vehicle pulls to one side

Test conditions before and during the road test

- Check all suspension components on the front and rear axles for damage.
- Check tyre pressure and correct if necessary.
- Check the tyres for external damage. Punctures, cuts, bubbles on the sidewalls, flat spots from braking and/or damage to the tread.
- Ask the customer if the tyre had been damaged by a nail or similar object and was repaired by a tyre dealer. It may be necessary to renew such tyres.
- Check tyres for even wear and tread depth.
- Check if all tyres are of the same type, manufacture and tread pattern ⇒ [page 2](#)
- If the tyres are non-directional, ensure that all DOT classifications on the tyre face outwards.
- Perform the road test on a road which is level, straight and ungrooved and does not drop off to one side.
- Perform the road test with the customer under the conditions specified above. Ask the customer to demonstrate the problem.



Note

There must be no cross wind during the road test.



If the complaint is justified, we recommend rotating the wheels and tyres as described below.

Before you begin, observe the following notes; otherwise your efforts may not have the desired effect.



Note

- ◆ *Mark the tyres before the first rotation, e.g.: FR, FL, RR and RL.*
- ◆ *After rotating wheels or reversing the tyre on its rim, you must observe very carefully how the vehicle behaves during the road test. Note how and what was changed.*
- ◆ *Assess the intensity of or a possible change in the tendency to pull to one side.*
- ◆ *For this purpose, it is important that the road tests are always performed by the same person on the same road. It is best to drive the „test course“ in both directions.*
- ◆ *Replacing a tyre with a new tyre does not guarantee that pulling to one side will be eliminated. Therefore it is recommended as a first step to carry out the strategic rotation of the wheels as described below.*
- ◆ *If there are large differences in the tread depth of the tyres on the front and rear axles, the tyres with the deeper tread should always be mounted on the front axle.*

7.4 Strategic rotation of wheels for non-directional tyres

↓	
Perform a road test to determine whether a vehicle is pulling to one side and if so, which side.	
↓	
If the vehicle pulls to one side, interchange the front wheels	
↓	
Carry out road test	
Vehicle travels in a straight line - END	
Vehicle pulls to other side	Vehicle pulls to the same side

Protected by copyright. Copying for personal use, in part or in whole, is not permitted unless authorised by SKODA AUTO A. S. SKODA AUTO A. S. does not guarantee or accept any liability with respect to the content of this document. SKODA AUTO A. S.



↓		↓	
Reverse one front tyre on its rim (direction of rotation is reversed)		Interchange front and rear tyres	
↓		↓	
Carry out road test		Carry out road test	
Vehicle travels in a straight line - END		Vehicle travels in a straight line - END	
Vehicle does not travel in a straight line		Vehicle does not travel in a straight line	
↓		↓	
Interchange the front and rear wheels		Vehicle pulls to other side	No change
↓		↓	↓
Carry out road test		Reverse one front tyre on its rim (direction of rotation is reversed)	Check alignment of front and rear wheels and adjust if necessary If the alignment is correct, contact Product Support
Vehicle travels in a straight line - END			
Vehicle does not travel in a straight line			
↓			
Interchange front wheels			
↓		↓	
Carry out road test		Carry out road test	
Vehicle travels in a straight line - END	Vehicle does not travel in a straight line	Vehicle travels in a straight line - END	
	↓	Vehicle does not travel in a straight line	
	Mount new tyres on front axle	Mount new tyres on front axle	
	↓	↓	
	Carry out road test	Carry out road test	
	Vehicle travels in a straight line - END	Vehicle travels in a straight line - END	
	↓	↓	

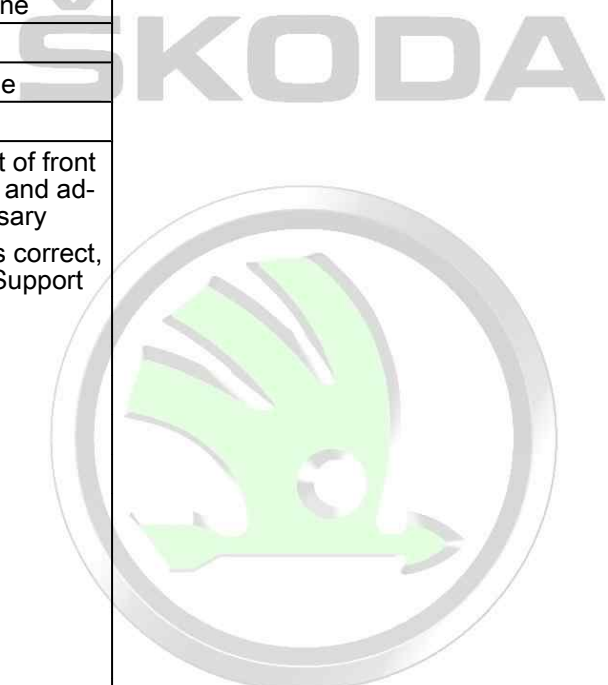

Protected by copyright. Copying for private or commercial purposes, in part or in whole, is not permitted unless authorised by SKODA AUTO A. S. SKODA AUTO A. S. does not guarantee or accept any liability with respect to the correctness of information in this document. Copyright by SKODA AUTO A. S.



Vehicle does not travel in a straight line; contact Product Support

7.5 Strategic rotation of wheels having unidirectional tyres

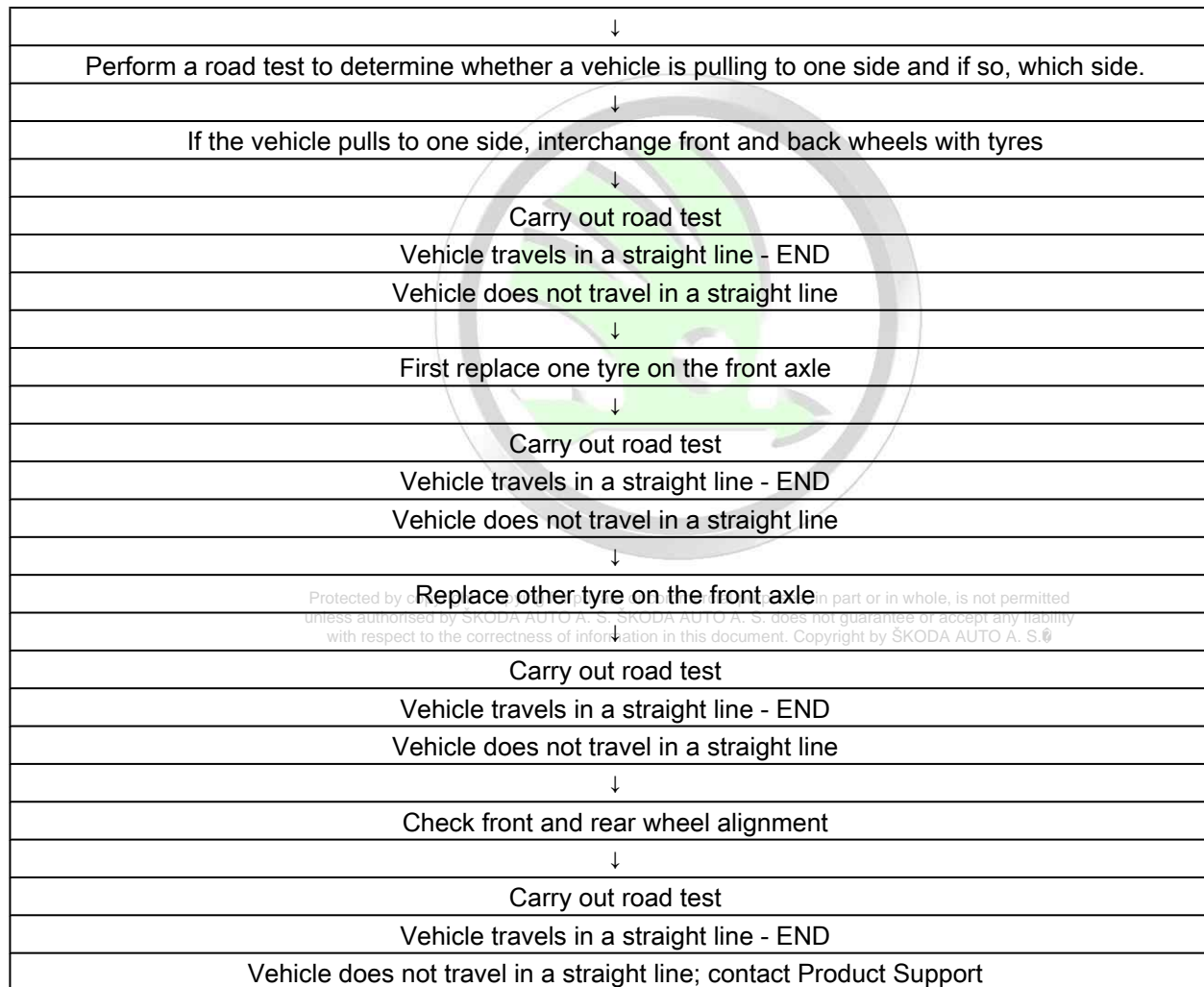

Protected by copyright. Reproduction in part or in whole, is not permitted unless authorised by ŠKODA AUTO A. S. ŠKODA AUTO A. S. does not guarantee or accept any liability with respect to the correctness of information in this document. Copyright by ŠKODA AUTO A. S. ©



ŠKODA



Protected by copyright. Copying for private or commercial purposes, in part or in whole, is not permitted unless authorised by ŠKODA AUTO A. S. ŠKODA AUTO A. S. does not guarantee or accept any liability with respect to the correctness of information in this document. Copyright by ŠKODA AUTO A. S. ©



8 Tyre damage

General information ⇒ [page 54](#)

Impact damage ⇒ [page 55](#)

Cuts ⇒ [page 57](#)

Damage caused by foreign bodies ⇒ [page 57](#)

Loss of air from tyre ⇒ [page 57](#)

Tyre pressure ⇒ [page 58](#)

Tyre damage due to insufficient tyre pressure ⇒ [page 59](#)

Rising tyre temperature caused by insufficient tyre pressure
⇒ [page 60](#)

Tyre damage due to fitting error (fitting damage) ⇒ [page 61](#)

ŠKODA

8.1 General information

As tyre damage can have serious consequences, you and the driver should regularly check the tyres to identify any problems at an early stage.

Damaged tyres cannot withstand driving conditions such: high speed, long distances, sporty driving, and so on.

Damage can be caused in a number of ways:

- ◆ Driving with insufficient tyre pressure
- ◆ Assembly error when tyres were fitted on rims
- ◆ Damage by embedding objects
- ◆ Ageing
- ◆ Improper storage



WARNING

Whenever a safety risk cannot be ruled out, the tyre must be renewed.

Copyright. Copying for private or commercial purposes, in part or in whole, is not permitted unless authorised by ŠKODA AUTO A. S. ŠKODA AUTO A. S. does not guarantee or accept any liability with respect to the correctness of information in this document. Copyright by ŠKODA AUTO A. S.



8.2 Impact damage

A swelling in the sidewall of the tyre indicates that the substructure of the carcass has been damaged.

Typical causes for such damage include, for example, driving over kerbs at a sharp angle.

Pinching the tyre in this way can damage the carcass.

The substructure of the tyre is stretched so far that individual fibres in the carcass may be broken.

The extent of the damage depends on the speed of impact, the angle of impact, the tyre pressure, the axle load and the type of obstacle.

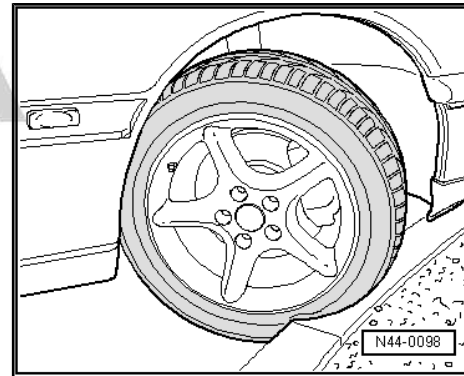

Pinch marks on tyre sidewall -arrows-



Note

- ◆ *Driving over kerbs should be avoided!*
- ◆ *If you cannot avoid driving over a kerb, you should do so very slowly and as square-on as possible.*

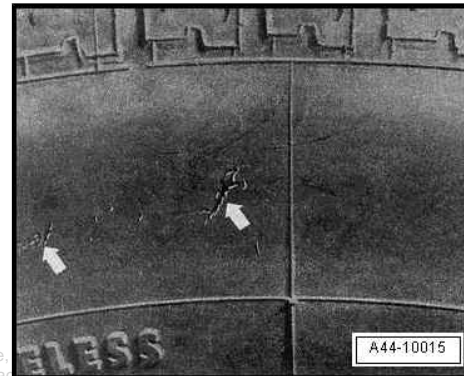

Protected by copyright. Copying for private or commercial purposes, in part or in whole, unless authorised by ŠKODA AUTO A. S. ŠKODA AUTO A. S. does not guarantee or accept any liability with respect to the correctness of information in this document. Copyright by ŠKODA AUTO A. S. ©



Interior view of a tyre with a punctured carcass

Due to a severe impact, the carcass was pinched on the wheel rim flange and is ruptured in the contact area.

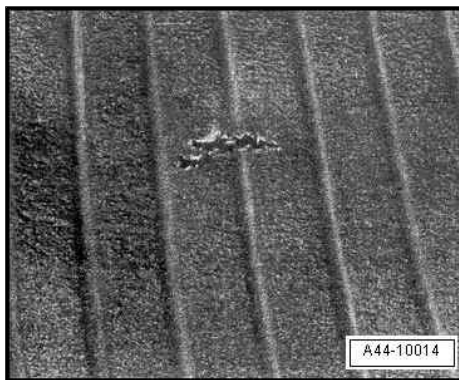

Damage inside tyre due to impact injury (double rupture)

Double rupture -arrows- caused by pinching when a kerb was driven over. Often not detectable from outside. Often not detectable from outside.

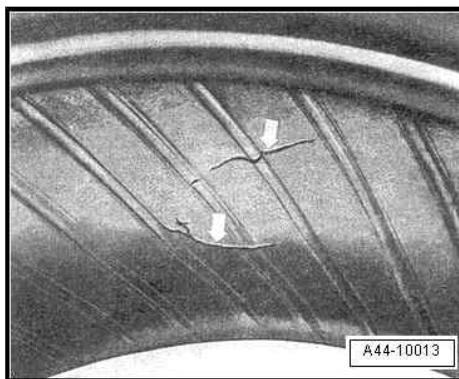

Protected by copyright. Copying for private or commercial purposes, in part or in whole, is not permitted unless authorised by ŠKODA AUTO A. S. ŠKODA AUTO A. S. does not guarantee or accept any liability with respect to the correctness of information in this document. Copyright by ŠKODA AUTO A. S. ©



8.3 Cuts

Cut caused by a sharp-edged obstacle -arrow-.



8.4 Damage caused by foreign bodies

Driving over hard, pointed objects like nails, screws and the like can pierce the tyre.

This always leads to tyre damage.

Damage due to embedded foreign body

Often, the object -marking- is so securely embedded in the tyre that it will not free itself even at higher speeds. Consequently, it can act as a plug and seal the tyre relatively well. This results in a gradual loss of pressure, which the driver will not notice immediately, but which can lead to sudden and complete tyre failure.



Note

No repair should be attempted on a steel belted tyre of which the structure has been punctured by a foreign body.

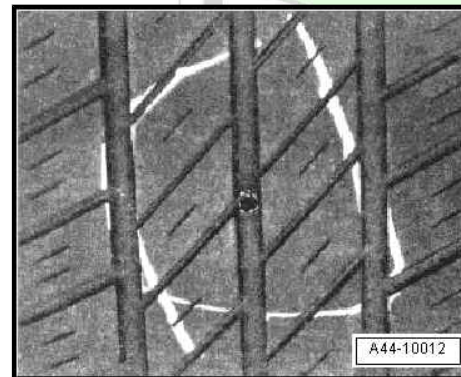

al purposes, in part or in whole, is not permitted
A. S. does not guarantee or accept any liability
document. Copyright by ŠKODA AUTO A. S. ©

8.5 Loss of air from tyre

If the customer complains of a “loss of air” from a tyre, it is essential that you check for embedded foreign bodies.



Note

No repair should be attempted on a steel belted tyre of which the structure has been punctured by a foreign body.

Corrosion can develop on the steel wires. This will always lead to the separation of the rubber from the steel belt.

Generally, one cannot determine when the foreign body was embedded. The tyre structure may already have been damaged as a result of driving with insufficient tyre pressure.

Damaged belt wires will sooner or later lead to separation of the rubber from the steel belt. As a result, the tyre can fail completely at some point long after the tyre was first damaged.

Tyre damage caused by foreign bodies is not covered by the warranty.

8.6 Tyre pressure

The tyre pressure must be checked regularly. We recommend checking the tyre pressure every two weeks. The correct tyre pressure is especially important on long trips or when carrying a heavy load. A sporty driving style also requires correct or even slightly increased tyre pressure.

Slow loss of tyre pressure

The slow loss of tyre pressure is especially problematic because even experienced drivers often do not notice it.

Insufficient tyre pressure and the related increase in flexing (internal friction) cause the tyre material to heat up considerably and may lead to the separation of the various components and rubber compounds.

In the end, the tyre is usually destroyed completely

⇒ [page 59](#) .

The cause for the slow pressure loss cannot always be determined because the tyre is severely damaged and structural components of the tyre are missing.



8.7 Tyre damage due to insufficient tyre pressure

The most common causes for tyre failure are minor external damage, a defective valve or a leaking rim due to corrosion or damage.

Separation of carcass and rubber

Excessive heating due to driving with substantially insufficient tyre pressure led to overheating and subsequent separation of the carcass from the rubber material -arrows-.

The tyre shown here was periodically driven with an inflation pressure which was insufficient for the load. Typical evidence for this is the circumferential scuffing along the bead caused by the wheel flange and also the discolouration. Small, furrowed creases are visible along the inside of the sidewall.

When the tyre rolls, strong shear forces develop between the layers of steel cord, especially at the ends of the belts.



Tyres with wide, circumferential furrows near the bead

Wide, circumferential furrows near the bead -arrows- indicate that the tyre was driven with insufficient pressure.

Driving a vehicle with insufficient tyre pressure or ignoring or not recognising tyre damage can have serious consequences.

The tyre can no longer withstand the forces which develop when the vehicle is driven.

The defects mentioned above severely restrict the function of the tyre. The rubber compounds separate, which results in the partial separation of tyre components or even its complete destruction.

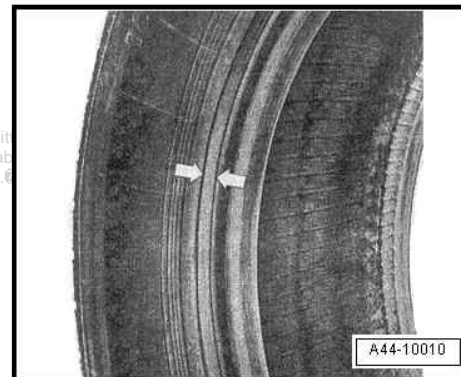



Tyres with stripped profile

Such damage usually develops over a longer period of time. If an already damaged tyre is exposed to high stress, the centrifugal forces which occur at high speeds can tear components off the tyre.

The figure shows a tyre with stripped tread due to travel with insufficient tyre pressure.



8.8 Rising tyre temperature caused by insufficient tyre pressure

The graph shows the temperature development of a tyre at a speed of 180 km/h.

A - Normal zone: When specified tyre pressure is maintained, the temperature will remain stable

B - Danger zone: When tyre pressure is 0.3 bar below specification, the temperature rises to above 120°C at higher speeds.

C - Critical temperature threshold: A tyre defect will develop

T - Temperature in °C

t - Travel time in minutes

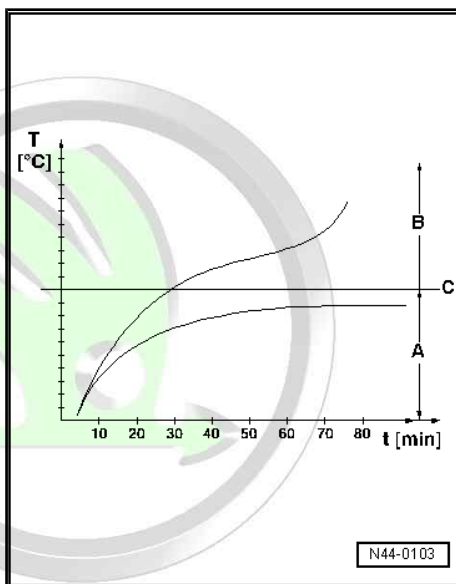



8.9 Tyre damage due to fitting error (fitting damage)

Bead core broken during tyre inflation

Modern radial tyres for passenger cars are mounted only on safety rims. Safety rims have a hump -1- running along the bead seat.

- 1 - Hump (double hump H 2), extended double hump (EH2)
- 2 - Wheel rim flange
- 3 - Inner rim shoulder (e.g. tapered rim shoulder)
- 4 - Rim
- 5 - Wheel
- 6 - Well
- 7 - Outer rim shoulder (e.g. tapered rim shoulder)

The hump prevents the tyre from being pressed out of the rim shoulder during travel with insufficient tyre pressure.

When the tyre is inflated, the bead of the tyre may not slip completely over the outer rim hump.

In this case, there is a danger of the bead core becoming overstretched if the tyre pressure is too high. A broken bead core cannot be detected from the outside.

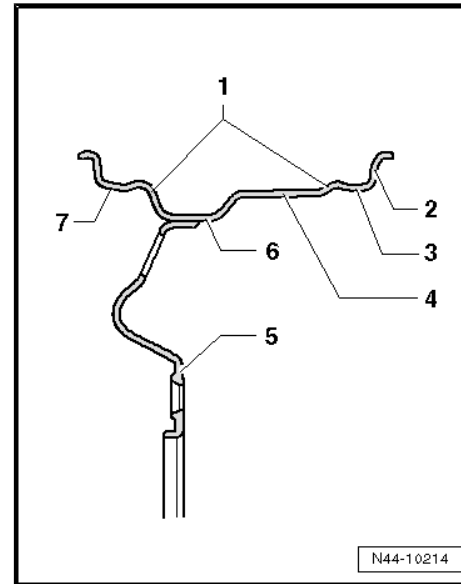

WARNING

Tyres with damaged bead cores are not seated safely and securely on the rim. Such tyres are a safety risk!

In addition, there is a risk of the partly broken bead core breaking apart during continued operation and the tyre could suddenly tear open. If the bead core breaks during inflation, the carcass will also be destroyed.



Tyre with broken bead core and destroyed carcass

The figure shows a tyre with a broken bead core and destroyed carcass as a result of excess pulling force during fitting.

Bead damage due to faulty or incorrect tyre fitting with tyre-fitting machine

The following errors, which may occur when tyres are fitted, can lead to severe tyre damage:

- ◆ If the opposite tyre bead is not seated completely in the rim well when the upper bead is rolled in on the tyre fitting machine ⇒ [page 61](#)
- ◆ If the fitting head is improperly adjusted.
- ◆ If the edge of the fitting roller rolls onto the bead.
- ◆ If the guide rollers are worn or have sharp edges.

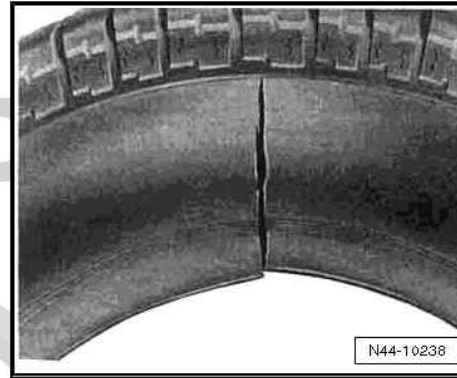



If the tyre bead is split.

In these cases, the bead, which is under great tension, can be cut into in the direction of rotation, split and/or be pinched off down to the core wire.

It is often possible to identify the tracks of the guide roller as it was applied or ran off where the damage occurred.



Note

Both tyre beads as well as the rim shoulders must always be coated with assembly paste .

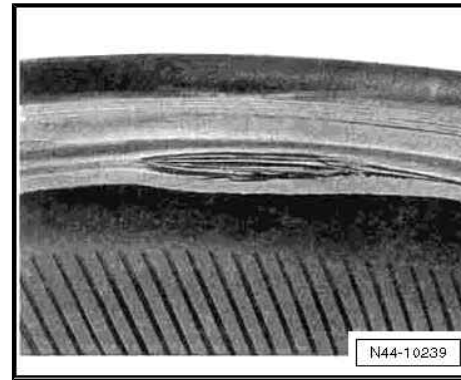

If fitting damage remains undetected, there is a danger that the tyre will fail later during operation.

THEREFORE!

- ◆ Never fit a tyre without using assembly paste .
- ◆ Do not allow the bead seating pressure to exceed 3 bar.
- ◆ Do not allow the tyre inflation pressure to exceed 4 bar.
- ◆ When the tyre has been fitted, reduce the tyre pressure to the specified value.

ŠKODA



Protected by copyright. Copying for private or commercial purposes, in part or in whole, is not permitted unless authorised by ŠKODA AUTO A. S. ŠKODA AUTO A. S. does not guarantee or accept any liability with respect to the correctness of information in this document. Copyright by ŠKODA AUTO A. S. ©



9 Rolling resistance optimised tyres

The energy loss caused by the deformation of the tyre when rolling is known as rolling resistance.

With rolling resistance optimised tyres the deformation is greatly reduced by a revised design and the use of optimised tread compositions.

ŠKODA





10 Rims - basic information

Structure of wheel rims ⇒ [page 65](#)

Data on wheel rims ⇒ [page 67](#)

Care and maintenance of alloy wheel rims ⇒ [page 67](#)

Restoring alloy wheels ⇒ [page 68](#)

The rubber valve ⇒ [page 69](#)

10.1 Structure of wheel rim

ŠKODA



Protected by copyright. Copying for private or commercial purposes, in part or in whole, is not permitted unless authorised by ŠKODA AUTO A. S. ŠKODA AUTO A. S. does not guarantee or accept any liability with respect to the correctness of information in this document. Copyright by ŠKODA AUTO A. S. ©



1 - Wheel rim flange

- Stop for tyre side beading

2 - Hump (H2) on both shoulders of rim

- Prevents the tyre slipping off the shoulder of the rim while driving through tight bends

3 - Well

- Eases fitting/removal of tyre

A - Width of wheel rim

- Distance between tyre contact surfaces on both rim edges of wheel
- Dimensions in inches

B - Wheel rim diameter

- Distance between tyre contact surfaces on opposite tyre shoulders
- Dimensions in inches

C - Wheel offset

- Vertical distance between centre of wheel and wheel inner contact surface
- Dimensions in mm

D - Pitch circle diameter

- Diameter of circle for wheel bolt holes
- Dimensions in mm

E - Centre hole

- Used to centralize
- Dimensions in mm

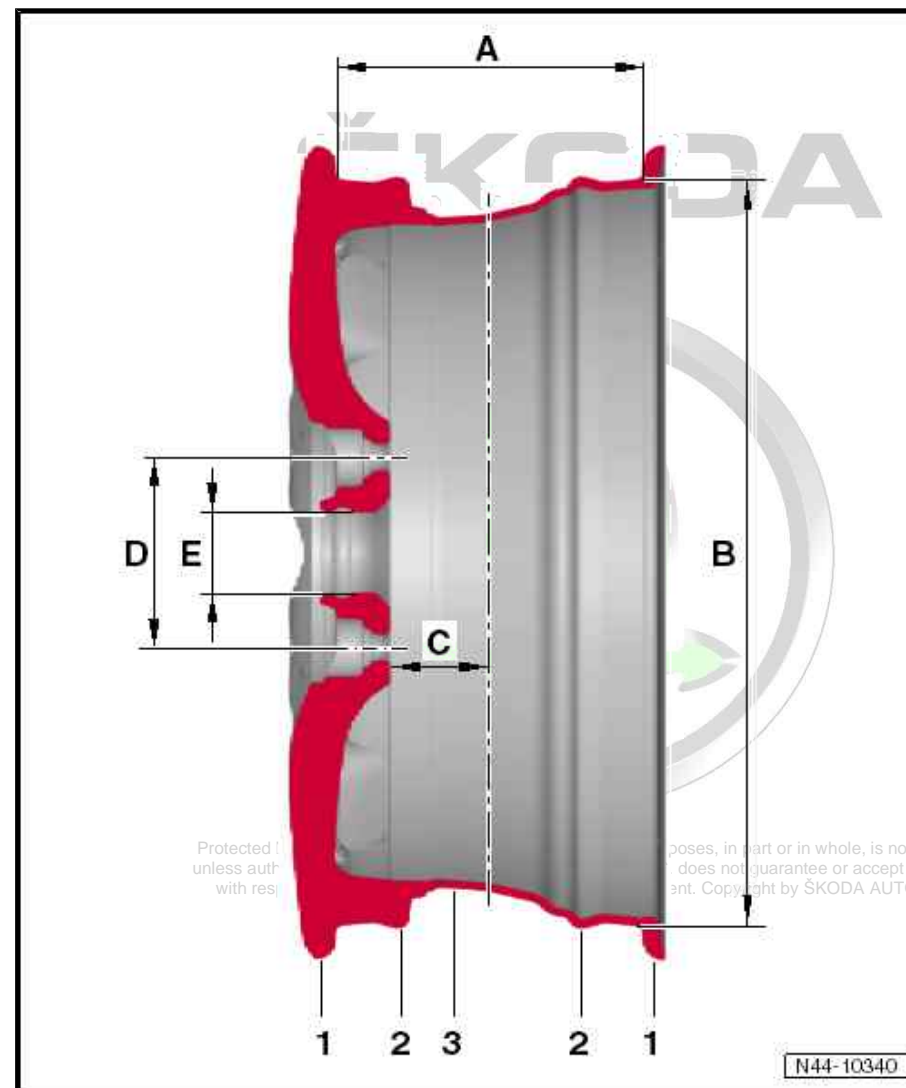



10.2 Data on wheel rims

There are several items of information on the wheel rims. The following example shows the information needed for unambiguous identification of the wheel:

Part number:	1Z0 601 025 R
Wheel size:	6 J × 15 6 - Rim width in inches J - Shape of wheel rim flange 15 - Rim diameter in inches
Wheel offset in mm:	43
Data on hump of rim shoulder:	H2

10.3 Care and maintenance of alloy wheel rims

Regular care is required to maintain the decorative appearance of alloy wheels over a long period of time.

In particular road salt and dust from brake abrasion must be thoroughly washed off every 2 weeks; otherwise the finish of the alloy wheel will suffer.

Cleaning agents

Suitable cleaning agents:

- ◆ Plain water or water with soft soap
- ◆ Water and essence of vinegar
- ◆ Alloy wheel cleansers without acids or strong solvents

Do not exceed the soaking time of the cleaning agent.

The shorter the recommended soaking time, the harsher and more aggressive the cleaning agent.

Protected by copyright. Copying for private or commercial purposes, in part or in whole, is not permitted unless authorised by ŠKODA AUTO A. S. ŠKODA AUTO A. S. does not guarantee or accept any liability with respect to the correctness of information in this document. Copyright by ŠKODA AUTO A. S. ©



Removing adhesive residue from glued balance weights on alloy rims

- ◆ Strong solvents and acids attack the finish on alloy wheels and the surface of the wheel becomes matt and milky. Therefore, these substances should not be used.
- ◆ To remove adhesive residue on alloy wheels, use alloy cleansers or a petrol-based cleanser. Do not exceed the soaking time of the cleaning agent.
- ◆ After cleaning or removing adhesive residue from wheels, rinse them with water.

10.4 Restoring alloy wheels



WARNING

Repairing a damaged wheel using heat treatment such as welding or the addition or removal of material is absolutely forbidden.

Damaged or deformed wheel rims or wheel rims with cracked or deformed wheel bolt holes may not be repaired.

Protected by copyright. Copying for private or commercial purposes, in part or in whole, is not permitted unless authorised by ŠKODA AUTO A. S. ŠKODA AUTO A. S. does not guarantee or accept any liability with respect to the correctness of information in this document. Copyright by ŠKODA AUTO A. S. ©



10.5 The rubber valve

- 1 - Valve body
- 2 - Valve core
- 3 - Valve cap

1. Valve body

The rubber valve for tubeless tyres is designed to create an air-tight seal in the hole in the rim. The elastic material of the rubber valve body presses tightly into the hole in the rim.

In the case of valves with a threaded metal base, a rubber seal is used to seal the rim. The lateral faces of the rim hole are sealing surfaces. They must therefore be free of rust and dirt and must not be damaged.

2. Valve core

The valve insert has the most important job in the valve. It creates a seal and enables the regulation of the air pressure. The small flat seal on the valve core can only function correctly if it is free of foreign particles, dirt and moisture. The compressed air system must be free of water and oil!

3. Valve cap

A valve cap must always be screwed onto the valve. It prevents dirt from getting into the valve. Dirt which may be in the valve would reach the seal of the valve plate when the tyre is inflated and cause a leak.

The valve must be replaced every time a new tyre is fitted.

If the vehicle is driven without caps on the valves, there is the danger that dirt may get into the valve. This leads to a gradual loss of air, which in turn can lead to the destruction of the tyre:

- ◆ Separation of carcass and rubber
- ◆ Wide, circumferential furrows near the bead
- ◆ Wide, circumferential furrows near the bead

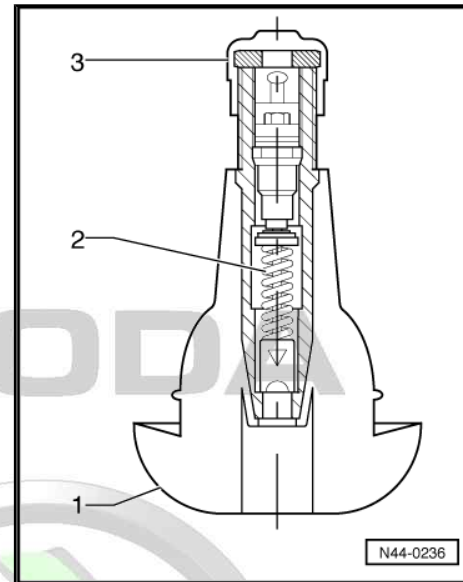

**WARNING**

The valve cap must be fitted tightly to ensure air-tight sealing.

ŠKODA



Protected by copyright. Copying for private or commercial purposes, in part or in whole, is not permitted unless authorised by ŠKODA AUTO A. S. ŠKODA AUTO A. S. does not guarantee or accept any liability with respect to the correctness of information in this document. Copyright by ŠKODA AUTO A. S. ©



11 Fitting wheels

Replacing wheels ⇒ [page 71](#)

Instructions for changing or fitting wheels ⇒ [page 71](#)

Notes on use of temporary spare wheels ⇒ [page 75](#)

11.1 Rotating wheels

Vehicles with front-wheel drive exhibit more tread wear on the front wheels due to the greater forces they have to transmit.

In order for all 4 wheels on the vehicle to have the same service life, we recommend rotating the front and rear wheels and tyres.

Ensure that uni-directional tyres are not reversed.

The longer the tyre runs at one position, the more it wears at certain points. Therefore it is recommended to rotate the wheels at short intervals, for example every 5,000 km.

Diagonal rotation is possible only with non-directional tyres. This method of wheel rotation is especially advantageous in the case of saw-tooth wear.

If saw-tooth wear has already progressed and the tread is worn to more than 50%, only slight improvements would be achieved and rotation is not recommended. The elasticity of the tread blocks declines and the saw-tooth wear does not progress.

11.2 Instructions for changing or fitting wheels



WARNING

Perform the checks and follow the instructions listed below. This is important to ensure that the wheel bolts and the wheels are properly secured.



Protected by copyright. Copying for private or commercial purposes, in part or in whole, is not permitted unless authorised by ŠKODA AUTO A. S. ŠKODA AUTO A. S. does not guarantee or accept any liability with respect to the correctness of information in this document. Copyright by ŠKODA AUTO A. S. ©



- Check to ensure that contact surfaces -arrows- on brake disc are free of corrosion and dirt.

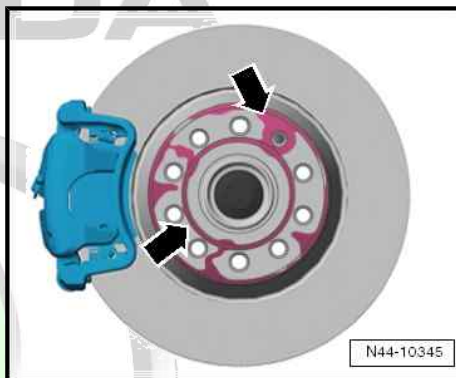

- Check to ensure that contact surface -arrow- on centring seat of brake disc are free of corrosion and dirt.

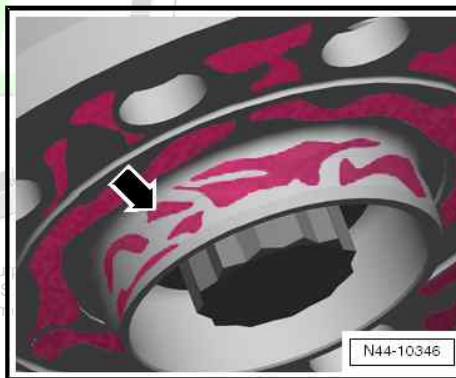

Protected by copyright. Copying for private or commercial purposes without the written permission of ŠKODA AUTO A. S. is prohibited. ŠKODA AUTO A. S. is not responsible for the correctness of information in this document.

- Check to ensure that contact surface -arrow- on inner side of wheel (rim) and also centring seat of rim are free of corrosion and dirt.
- The concave seats * in the holes for the wheel bolts and the threads of the wheel bolts must also be free of corrosion and dirt, oil or grease.

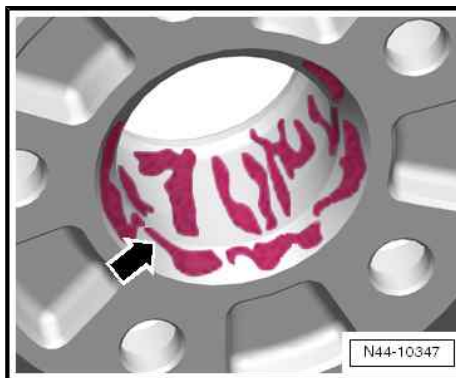

* The concave seat is the curved surface of a section of a sphere cut by a plane



- Check whether the wheel bolts can be easily screwed in by hand. The thread of the wheel bolts must not come into contact with the bore in the brake disc -arrow-.

If the thread of the wheel bolt touches the hole -arrow-, the brake disc must be turned relative to the wheel hub accordingly.

Remove dirt and corrosion, oil or grease from the contact surfaces, threads in the wheel hub and/or wheel bolts as necessary.



WARNING

Damaged, badly corroded or difficult to remove wheel bolts must be replaced.

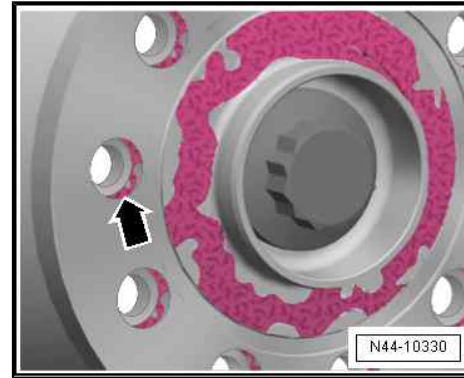

Fitting wheels

- Preserve wheel centring seat.
- 1 - When fitting the wheel, screw in all wheel bolts uniformly by hand.
 - 2 - Tighten the wheel bolts in diagonal sequence to approx. 30 Nm.
 - 3 - Lower vehicle to the floor and tighten all wheel bolts diagonally to the specified torque using the torque wrench.



WARNING

Do not use an impact driver when screwing in the bolts!

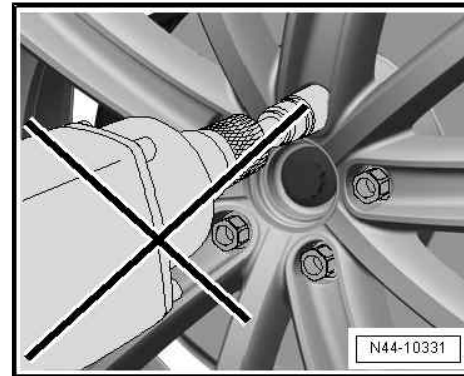

11.3 Protecting wheel centring seat against corrosion

Valid for light alloy and steel wheels

When a wheel is installed, wheel centring seat should be waxed with Wax spray -D 322 000 A2- to prevent corrosion between the wheel centring seat and the wheel rim.

Protected by copyright. Copying for private or commercial purposes, in part or in whole, is not permitted unless authorised by ŠKODA AUTO A. S. ŠKODA AUTO A. S. does not guarantee or accept any liability with respect to the correctness of information in this document. Copyright by ŠKODA AUTO A. S.®



- Remove wheel.
- Clean wheel centring seat of hub and wheel rim centring ring.
- Apply wax to centring ring -arrow- with a brush.

Ensure that only centring ring -arrow- but not contact surface of wheel rim has been waxed. Otherwise, the brakes will be soiled, which would reduce the braking efficiency.

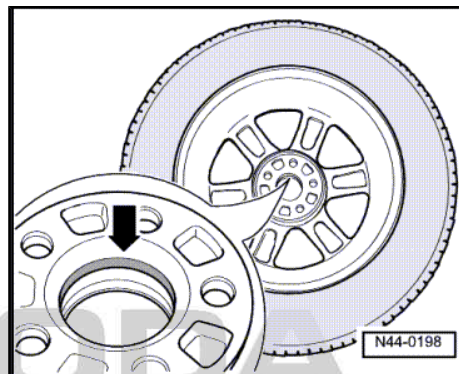

WARNING

Wheel bolts, contact surfaces of wheel hub and wheel rim and wheel hub threads must not be waxed. Never treat wheel securing bolts with lubricant or corrosion protection materials!

- Install wheel and tighten bolts or nuts.





11.4 Notes on use of temporary spare wheels

Inform your customers about the following notes and, if appropriate, refer also to the user's manual of the vehicle as the need arises.



Note

- ◆ *The spare wheel or temporary spare wheel is intended only for temporary use over short distances. Therefore, it must be replaced by a normal wheel as quickly as possible.*
- ◆ *After the temporary or spare wheel has been fitted, the tyre pressure must be checked as soon as possible. For the correct tyre pressure, please refer to the tyre pressure in the relevant vehicle or the relevant manual: Maintenance and repair, to be precise.*
- ◆ *On vehicles with the tyre pressure inspection system, it must be adapted again after changing the spare wheel ⇒ Operating instructions .*
- ◆ *Always observe the speed warning on the temporary spare wheel ("MAX 80 km/h" or "MAX 50 mph").*
- ◆ *Full acceleration, hard braking and driving fast through curves should be avoided.*
- ◆ *Never drive with more than one spare wheel or temporary spare wheel.*
- ◆ *The use of snow chains on the temporary spare wheel is not permitted for technical reasons.*
- ◆ *If it is necessary to travel with snow chains, the temporary spare wheel must be fitted on the rear axle even if the front tyre has been damaged.*



12 Wheel/tyre combinations

Permissible wheel/tyre combinations ⇒ [page 77](#) .

ŠKODA



Protected by copyright. Copying for private or commercial purposes, in part or in whole, is not permitted unless authorised by ŠKODA AUTO A. S. ŠKODA AUTO A. S. does not guarantee or accept any liability with respect to the correctness of information in this document. Copyright by ŠKODA AUTO A. S. ©



12.1 Permissible wheel-tyre combinations



Note

- ◆ *Only tyres of the same size and type may be fitted to the vehicle with front-wheel drive, however the same brand and tread pattern must always be fitted to wheels on the same axle. It is exceptionally allowed to use a different tyre temporarily in the event of breakdown. Take into account a change in driving and braking behaviour.*
- ◆ *Only tyres of the same size, type, brand and tread pattern may be fitted to the vehicle with four-wheel drive. It is exceptionally allowed to use a different tyre temporarily in the event of breakdown. Take into account a change in driving and braking behaviour.*
- ◆ *Use wheel bolts with spherical collar and a thread of M14 x 1.5 - tightening torque: 120 Nm.*
- ◆ *Only use authorised rims on the relevant vehicle.*
- ◆ *When replacing rims always use wheel bolts that belong to these rims (different length and spherical cap shape).*
- ◆ *If winter tyres are used with a lower speed rating than the maximum permissible driving speed, it has to be pointed out with a sticker providing an additional note which must be fixed in the field of vision of the driver.*
- ◆ *The information given on the sticker determines the maximum permissible driving speed for the winter tyres fitted, which must not be exceeded during the operation of the vehicle.*
- ◆ *The note on the sticker can be replaced with the system installed in the vehicle for life (for example the onboard computer) ⇒ Operating instructions .*
- ◆ *Also observe the national legislation.*
- ◆ *On vehicles with the tyre pressure inspection system, it must be adapted again after changing one or several wheels ⇒ Operating instructions .*

uses, in part or in whole, is not permitted
SKODA AUTO A. S. does not guarantee or accept any liability
with respect to the correctness of information in this document. Copyright by SKODA AUTO A. S. ©



Caution

Tyres that are more than 6 years old must only be used in case of emergency and while driving very carefully.



Protected by copyright. Copying for private or commercial purposes, in part or in whole, is not permitted unless authorised by ŠKODA AUTO A. S. ŠKODA AUTO A. S. does not guarantee or accept any liability with respect to the correctness of information in this document. Copyright by ŠKODA AUTO A. S. ©

Permissible wheel-tyre combinations (except version Scout, Green Line and RS)

Engine	Tyre size	Rim	Offset "OS" (mm)	Snow chains permitted		Number of locating holes x bolt-hole circle diameter (mm)	Centre hole diameter (mm)
				Yes	No		
1.2 ltr./77 kW TSI	195/65 R15 91H/V	6J x 15	47	X		5x112	57
	195/65 R15 91H	6,5J x 15	50		X		
	205/60 R15 91V/H	6,5J x 15	50		X		
	205/55 R16 91H	6J x 16	50	X			
	205/55 R16 91V/H	6,5J x 16	50		X		
	205/50 R17 89H	6J x 17	45	X			
	225/45 R17 91W/H	7J x 17	54		X		
1.4 ltr./55 kW 1.4 ltr./59 kW	195/65 R15 91T/H/V	6J x 15	47	X		5x112	57
	195/65 R15 91T	6,5J x 15	50		X		
	205/60 R15 91V/T	6,5J x 15	50		X		
	205/55 R16 91T	6J x 16	50	X			
	205/55 R16 91V/T	6,5J x 16	50		X		
	205/50 R17 89T	6J x 17	45	X			
	225/45 R17 91W/T	7J x 17	54		X		
1.4 ltr./90 kW TSI	195/65 R15 91V	6J x 15	47	X		5x112	57
	195/65 R15 91V	6,5J x 15	50		X		
	205/60 R15 91V	6,5J x 15	50		X		
	205/55 R16 91V	6J x 16	50	X			
	205/55 R16 91V	6,5J x 16	50		X		
	205/50 R17 89V	6J x 17	45	X			
	225/45 R17 91V/W	7J x 17	54		X		
1.6 ltr./75 kW 1.6 ltr./85 kW FSI 1.6 ltr./77 kW TDI CR 1.9 ltr./77 kW TDI PD	195/65 R15 91H/V	6J x 15	47	X		5x112	57
	195/65 R15 91H	6,5J x 15	50		X		
	205/60 R15 91H/V	6,5J x 15	50		X		
	205/55 R16 91H	6J x 16	50	X			
	205/55 R16 91H/V/W	6,5J x 16	50		X		
	205/50 R17 89H	6J x 17	45	X			

Protected by copyright. Copying for private or commercial purposes, in part or in whole, is not permitted unless authorised by SKODA AUTO A. S. SKODA AUTO A. S. does not guarantee or accept any liability with respect to the correctness of information in this document. Copyright by SKODA AUTO A. S. ©



Engine	Tyre size	Rim	Offset "OS" (mm)	Snow chains permitted		Number of locating holes x bolt-hole circle diameter (mm)	Centre hole diameter (mm)
				Yes	No		
	225/45 R17 91H/W	7J x 17	54		X		
2.0 ltr./110 kW FSI 2.0 ltr./100 kW TDI PD 2.0 ltr./103 kW TDI PD	195/65 R15 91V	6J x 15	47	X		5x112	57
	195/65 R15 91V	6,5J x 15	50		X		
	205/60 R15 91V	6,5J x 15	50		X		
	205/55 R16 91V	6J x 16	50	X			
	205/55 R16 91V/W	6,5J x 16	50		X		
	205/50 R17 89V	6J x 17	45	X			
	225/45 R17 91V/W	7J x 17	54		X		
1.8 ltr./118 kW TSI 1.8 ltr./112 kW TSI	195/65 R15 91V	6J x 15	47	X		5x112	57
	195/65 R15 91V	6,5J x 15	50		X		
	205/60 R15 91V	6,5J x 15	50		X		
	205/55 R16 91V	6J x 16	50	X			
	205/55 R16 91V/W	6,5J x 16	50		X		
	205/50 R17 93V	6J x 17	45	X			
	225/45 R17 91V/W	7J x 17	54		X		
2.0 ltr./81 kW TDI CR 2.0 ltr./100 kW TDI CR 2.0 ltr./103 kW TDI CR	195/65 R15 91V	6J x 15	47	X		5x112	57
	195/65 R15 91V	6,5J x 15	50		X		
	205/60 R15 91V	6,5J x 15	50		X		
	205/55 R16 91V	6J x 16	50	X			
	205/55 R16 91V/W	6,5J x 16	50		X		
	205/50 R17 93V	6J x 17	45	X			
	225/45 R17 91V/W	7J x 17	54		X		

- ◆ Tyre pressure values → Maintenance ; Booklet Octavia II as well as sticker on the fuel-tank cap
- ◆ Offset - abbreviation OS

Permissible wheel-tyre combinations version Scout

Engine	Tyre size	Rim	Offset "OS" (mm)	Snow chains permitted		Number of locating holes x bolt-hole circle diameter (mm)	Centre hole diameter (mm)
				Yes	No		
1.8 ltr./118 kW TSI	205/55 R16 91V	6J x 16	50	X		5x112	57
	225/50 R17 94W/V	7J x 17	50		X		
	205/50 R17 93V	6J x 17	45	X			
2.0 ltr./110 kW FSI	205/55 R16 91H	6J x 16	50	X		5x112	57
	225/50 R17 94W / H	7J x 17	50		X		
	205/50 R17 93H	6J x 17	45	X			
2.0 ltr./103 kW TDI PD 2.0 ltr./103 kW TDI CR	205/55 R16 91H	6J x 16	50	X		5x112	57
	225/50 R17 94W / H	7J x 17	50		X		
	205/50 R17 93H	6J x 17	45	X			

- ◆ Tyre pressure values ⇒ Maintenance ; Booklet Octavia II as well as sticker on the fuel-tank cap
- ◆ Offset - abbreviation OS

Permissible wheel-tyre combinations version RS

Engine	Tyre size	Rim	Offset "OS" (mm)	Snow chains permitted		Number of locating holes x bolt-hole circle diameter (mm)	Centre hole diameter (mm)
				Yes	No		
2.0 ltr./147 kW FSI	205/55 R16 91W	6J x 16	50	X		5x112	57
	225/45 R17 91W	7J x 17	54		X		
	205/50 R17 91W	6J x 17	45	X			
	225/40 R18 92Y / W	7,5J x 18	51		X		
2.0 ltr./125 kW TDI PD 2.0 ltr./125 kW TDI CR	205/55 R16 91V	6J x 16	50	X		5x112	57
	225/45 R17 91W	7J x 17	54		X		
	225/45 R17 91V	7J x 17	54		X		
	205/50 R17 93V	6J x 17	45	X			
	225/40 R18 92Y / V	7,5J x 18	51		X		

- ◆ Tyre pressure values ⇒ Maintenance ; Booklet Octavia II as well as sticker on the fuel-tank cap



- ◆ Offset - abbreviation OS

Permissible wheel-tyre combinations version Green Line

Engine	Tyre size	Rim	Offset "OS" (mm)	Snow chains permitted		Number of locating holes x bolt-hole circle diameter (mm)	Centre hole diameter (mm)
				Yes	No		
1.6 ltr./77 kW TDI CR	195/65 R15 91 H	6J x 15	47	X		5x112	57
	195/65 R15 91 H	6,5J x 15	50		X		
	205/55 R16 91H	6J x 16	50	X			
	205/55 R16 91H	6,5J x 16	50		X		

- ◆ Tyre pressure values ⇒ Maintenance ; Booklet Octavia II as well as sticker on the fuel-tank cap
- ◆ Offset - abbreviation OS

ŠKODA



Protected by copyright. Copying for private or commercial purposes, in part or in whole, is not permitted unless authorised by ŠKODA AUTO A. S. ŠKODA AUTO A. S. does not guarantee or accept any liability with respect to the correctness of information in this document. Copyright by ŠKODA AUTO A. S. ©

13 Wheels, Tyres

Wheels, Tyres - Instructions ⇒ [page 83](#)

Wheel with steel rim 6J x 15 or 6,5J x 16 ⇒ [page 84](#)

Wheel with a light alloy rim 6J x 15 ⇒ [page 85](#)

Wheel with a light alloy rim 6.5J x 15 ⇒ [page 87](#)

Wheel with a light alloy rim 6.5J x 16 ⇒ [page 89](#)

Wheel with a light alloy rim 7J x 17 ⇒ [page 91](#)

Wheel with a light alloy rim 7,5J x 18 ⇒ [page 93](#)

Spare wheel ⇒ [page 95](#)

13.1 Wheels, Tyres - Instructions

Permissible wheel-tyre combinations ⇒ [page 77](#)

Further information can be found in the ⇒ instructions for use .

Tyre assembly:

For tyre assemblies your tyre assembly device must be equipped with a tyre assembly head provided for these rims.



WARNING

Otherwise there is a risk of damage to the rim.

If your tyre assembly device is not yet retrofitted, please contact the manufacturer for this device.

General notes

For safety reasons never change tyres individually but at least in axle pairs.

Tyres with the greatest tread depth must always be fitted at the front.

It is recommended to fit tyres of the same make, same type and tread pattern on all wheels.

When replacing the rim or the tyre always replace the rubber valve.

Mount the tyre with the DOT marking pointing towards the outside of the wheel. This applies only to the left side of the vehicle for a directional tyre tread pattern.

For a directional tyre tread pattern mount a wheel/tyre combination for the right side of the vehicle as spare wheel.



WARNING

Only use those tyres or rims on your vehicle which have been approved by Skoda Auto.

This information is dependant on the corresponding national legislation and standards.



13.2 Wheel with steel rim 6J x 15 or 6,5J x 16



Note

- ◆ If the steel rim has to be fixed with an anti-theft wheel bolt, then this wheel bolt must be installed in the hole directly next to the valve. The wheel trim cap must then be attached starting at the valve.
- ◆ Because of design variations the steel rim and wheel trim cap may differ from the figure.
- ◆ The contact surface tread may differ from the shown contact surface tread.

1 - Tyres

2 - Steel rim

- 6J x 15, ET 47

3 - Wheel bolt, anti-theft 120 Nm

- M14 x 1.5 x 27.5

4 - Adapter for anti-theft wheel bolt

- included in tool kit
- Master set for wheel bolts -T40004- or -T10101-

5 - Wheel bolt, 120 Nm

6 - Balancing weights

- max. 60 g allowed per rim flange

7 - Retaining spring for balancing weights

8 - Valve

- only use valve in accordance with ⇒ Electronic catalogue of original parts

9 - Pull-off hook

- included in tool kit

10 - Wheel bolt key

- included in tool kit

11 - Wheel trim cap

- different version ⇒ electronic catalogue of original parts
- pull off with pull-off hook - Pos. 9

12 - Steel rim

- 6.5J x 16, ET 50

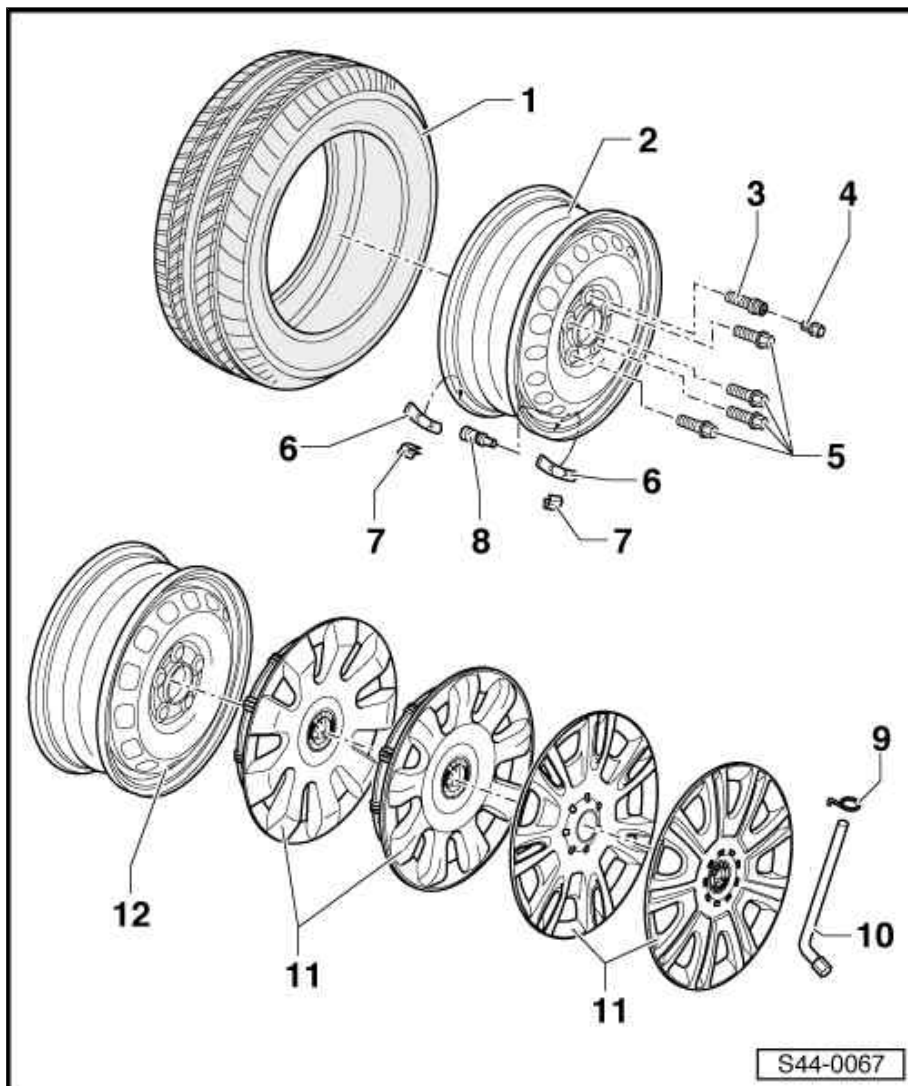

Protected by copyright. Copying for private or commercial purposes, in part or in whole, is not permitted unless authorised by ŠKODA AUTO A. S. ŠKODA AUTO A. S. does not guarantee or accept any liability for correctness of information in this document. Copyright by ŠKODA AUTO A. S. ©

13.3 Wheel with a light alloy rim 6J x 15



Note

- ◆ *The light alloy rim and wheel trim cap may differ from the figure.*
- ◆ *The contact surface tread may differ from the shown contact surface tread.*

1 - Tyres

2 - Light-alloy rim

- 6J x 15, ET 47

3 - Light-alloy rim

- 6J x 15, ET 47

4 - Wheel bolt, anti-theft 120 Nm

- M14 x 1.5 x 27.5

5 - Cap

- for anti-theft wheel bolt - Pos. 4
- pull off with pull-off shackle - Pos. 8

6 - Adapter for anti-theft wheel bolt

- included in tool kit
- Master set for wheel bolts -T40004- or -T10101-

7 - Wheel trim cap

- can only be removed once the wheel has been removed
- removing and installing



Note

Do not use a pull-off hook or other tools, e.g. screwdriver as this could damage the wheel trim cap.

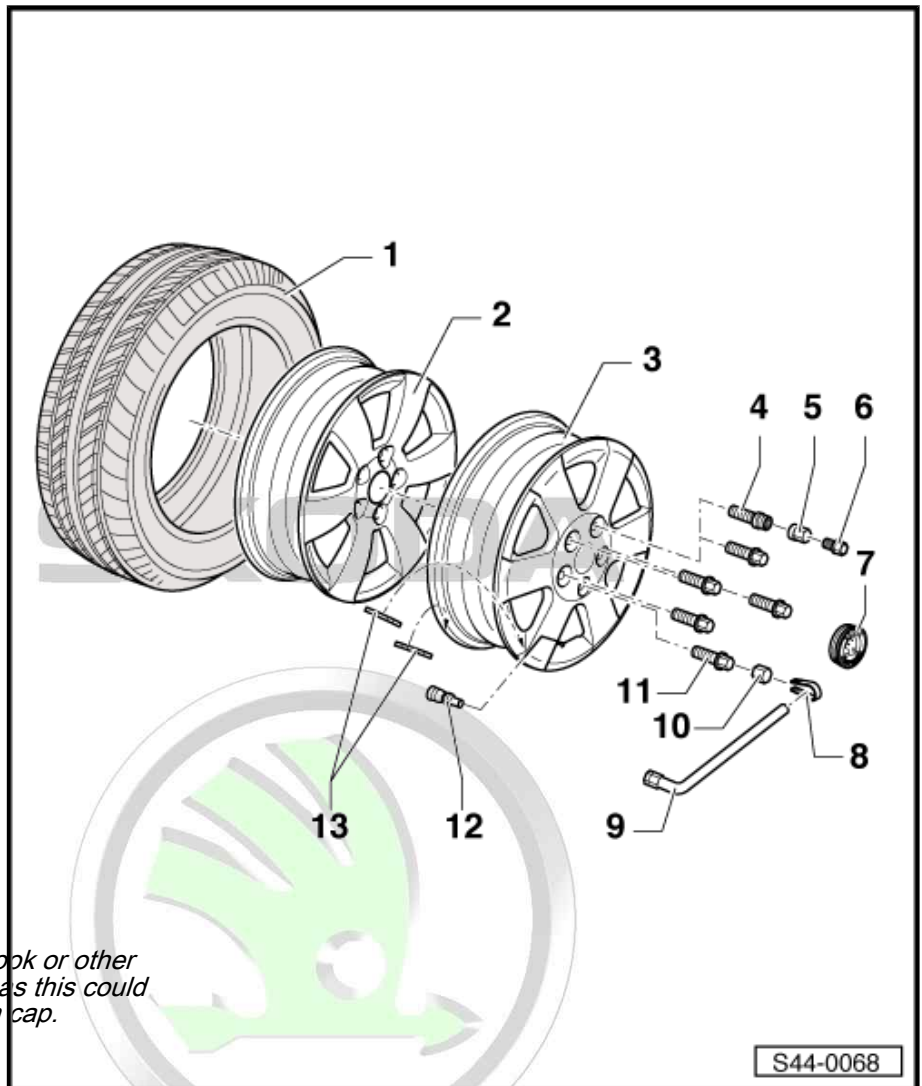

Removing:

Push the wheel trim cap towards the outside from the inside of the rim.

Installing:

Push-in the wheel trim cap from the outside of the rim, audible click.

Protected by copyright. Copying for private or commercial purposes, in part or in whole, is not permitted without the prior written consent of ŠKODA AUTO A. S. ŠKODA does not guarantee or accept any liability with respect to the correctness of information in this document. Copyright by ŠKODA AUTO A. S. ©

8 - Pull-off shackle

- included in tool kit

9 - Wheel bolt key

- included in tool kit

10 - Cap

- for wheel bolt - Pos. 11
- pull off with pull-off shackle - Pos. 8



11 - Wheel bolt, 120 Nm

- M14 x 1.5 x 27.5

12 - Valve

- Assignment ⇒ Electronic Catalogue of Original Parts

13 - Adhesive wheel weights

- max. 60 g allowed per rim flange
- Fitting position and glueing procedure of the self-adhesive balancing weights ⇒ [page 86](#)

Fitting position of the adhesive wheel weights

a - 18 +1 mm

1 - Adhesive wheel weight on the outside of the rim

2 - Adhesive wheel weight on the inside of the rim

Glue balancing weights:

- self-adhesive
- max. 60 g allowed per rim flange
- perform the glueing at room temperature
- Remove any dirt and grease from the point to be glued on the light alloy rim, e.g. with cleaning solution -D 009 401 04-
- Remove the protective foil
- Do not touch if necessary do not clog up with dirt the adhesive surface
- Stick balancing weights onto the specified surfaces

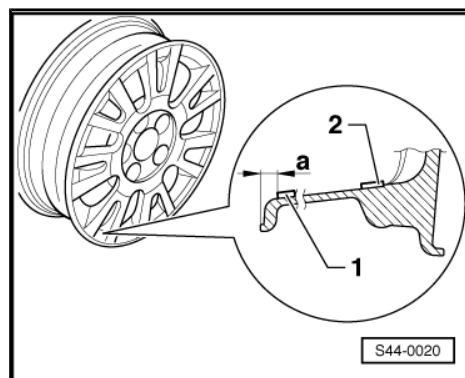

ŠKODA



13.4 Wheel with a light alloy rim 6.5J x 15



Note

- ◆ The light alloy rim and wheel trim cap may differ from the figure.
- ◆ The contact surface tread may differ from the shown contact surface tread.

1 - Tyres

2 - Light-alloy rim

- 6.5J x 15, ET 50

3 - Light-alloy rim

- 6.5J x 15, ET 50

4 - Wheel bolt, anti-theft 120 Nm

- M14 x 1.5 x 27.5

5 - Cap

- for anti-theft wheel bolt - Pos. 4
- pull off with pull-off shackle - Pos. 8

6 - Adapter for anti-theft wheel bolt

- included in tool kit
- Master set for wheel bolts -T40004- or -T10101-

7 - Wheel trim cap

- can only be removed once the wheel has been removed
- removing and installing



Note

Do not use a pull-off hook or other tools, e.g. screwdriver as this could damage the wheel trim cap.

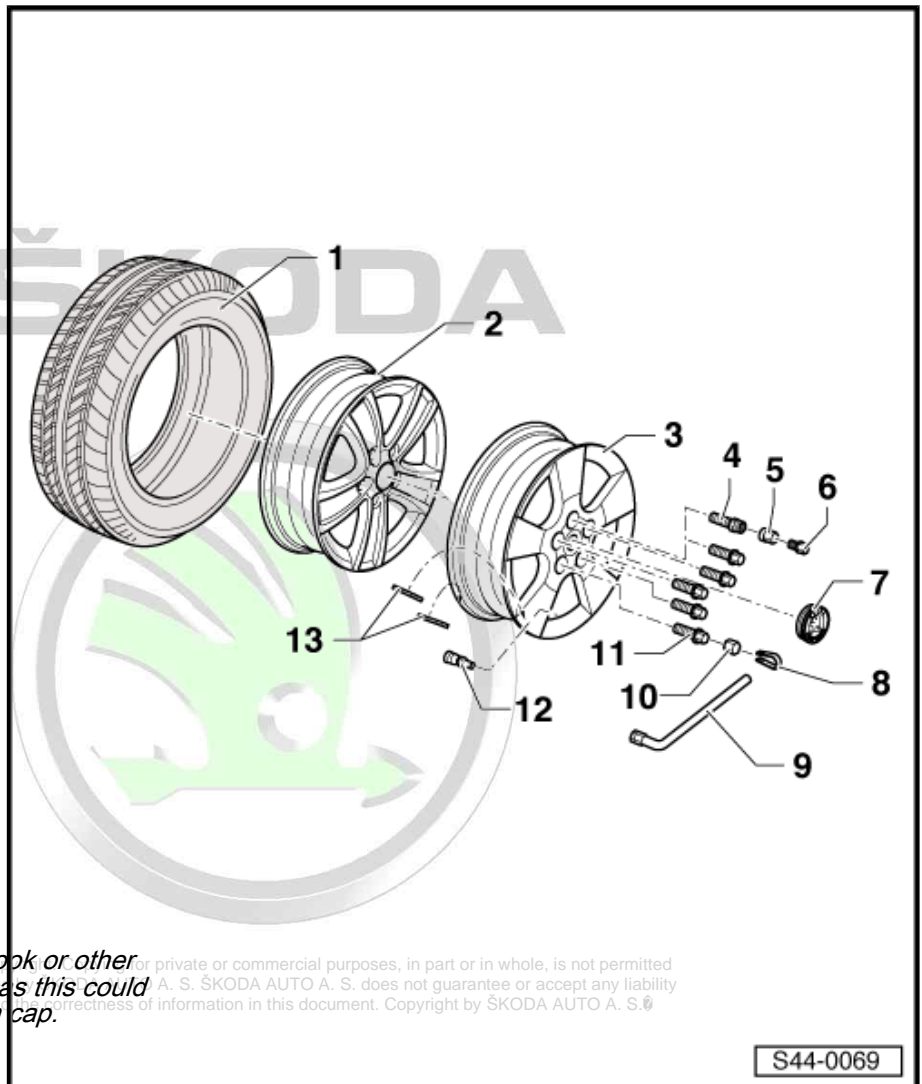

Removing:

Push the wheel trim cap towards the outside from the inside of the rim.

Installing:

Push-in the wheel trim cap from the outside of the rim, audible click.

8 - Pull-off shackle

- included in tool kit

9 - Wheel bolt key

- included in tool kit

10 - Cap

- for wheel bolt - Pos. 11
- pull off with pull-off shackle - Pos. 8

S44-0069



11 - Wheel bolt, 120 Nm

- M14 x 1.5 x 27.5

12 - Valve

- Assignment ⇒ Electronic Catalogue of Original Parts

13 - Adhesive wheel weights

- max. 60 g allowed per rim flange
- Fitting position and glueing procedure of the self-adhesive balancing weights ⇒ [page 88](#)

Fitting position of the adhesive wheel weights

a - 18 +1 mm

1 - Adhesive wheel weight on the outside of the rim

2 - Adhesive wheel weight on the inside of the rim

Glue balancing weights:

- self-adhesive
- max. 60 g allowed per rim flange
- perform the glueing at room temperature
- Remove any dirt and grease from the point to be glued on the light alloy rim, e.g. with cleaning solution -D 009 401 04-
- Remove the protective foil
- Do not touch if necessary do not clog up with dirt the adhesive surface
- Stick balancing weights onto the specified surfaces

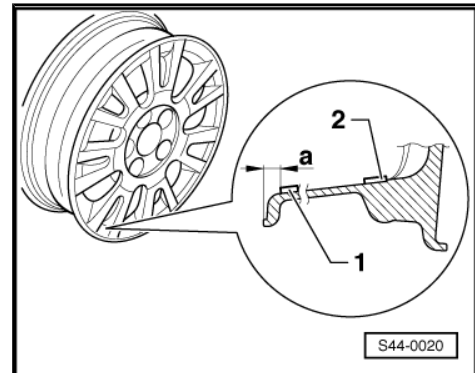

ŠKODA



Protected by copyright. Copying for private or commercial purposes, in part or in whole, is not permitted unless authorised by ŠKODA AUTO A. S. ŠKODA AUTO A. S. does not guarantee or accept any liability with respect to the correctness of information in this document. Copyright by ŠKODA AUTO A. S. ©

13.5 Wheel with a light alloy rim 6.5J x 16



Note

- ◆ *The light alloy rim and wheel trim cap may differ from the figure.*
- ◆ *The contact surface tread may differ from the shown contact surface tread.*

1 - Light-alloy rim

- 6.5J x 16, ET 50

2 - Light-alloy rim

- 6.5J x 16, ET 50

3 - Light-alloy rim

- 6.5J x 16, ET 50

4 - Light-alloy rim

- 6.5J x 16, ET 50

5 - Tyres

6 - Light-alloy rim

- 6.5J x 16, ET 50

7 - Wheel bolt, anti-theft 120 Nm

- M14 x 1.5 x 27.5

8 - Cap

- for anti-theft wheel bolt - Pos. 7
- pull off with pull-off shackle - Pos. 11

9 - Adapter for anti-theft wheel bolt

- included in tool kit
- Master set for wheel bolts -T40004- or -T10101-

10 - Wheel trim cap

- can only be removed once the wheel has been removed
- removing and installing

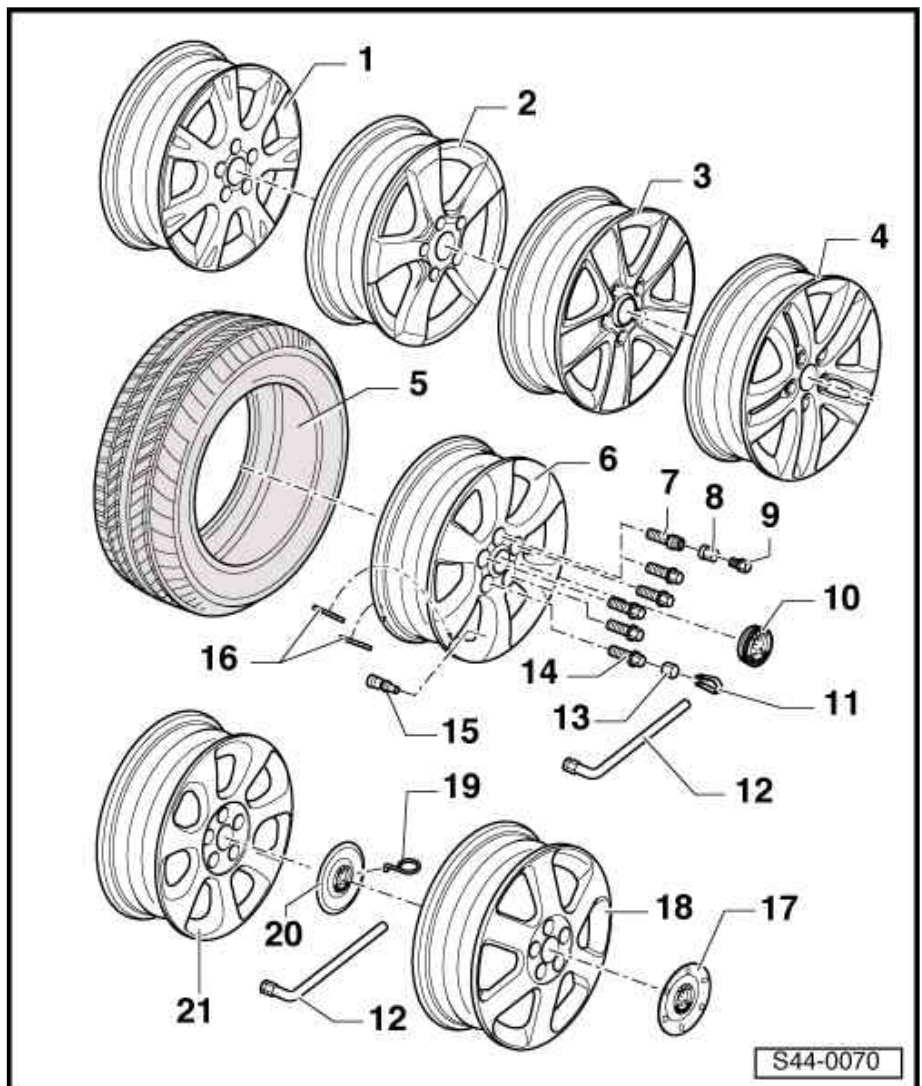

Note

Do not use a pull-off hook or other tools, e.g. screwdriver as this could damage the wheel trim cap.

Removing:

Push the wheel trim cap towards the outside from the inside of the rim.

Installing:

Push-in the wheel trim cap from the outside of the rim, audible click.



11 - Pull-off shackle

- included in tool kit

12 - Wheel bolt key

- included in tool kit

13 - Cap

- for wheel bolt - Pos. 14
- pull off with pull-off shackle - Pos. 11

14 - Wheel bolt, 120 Nm

- M14 x 1.5 x 27.5

15 - Valve

- Assignment ⇒ Electronic Catalogue of Original Parts

16 - Adhesive wheel weights

- max. 60 g allowed per rim flange
- Fitting position and glueing procedure of the self-adhesive balancing weights ⇒ [page 90](#)

17 - Wheel trim cap

- pull off with pull-off hook - Pos. 19

18 - Light-alloy rim

- 6.5J x 16, ET 50

19 - Pull-off hook

- included in tool kit

20 - Wheel trim cap

- pull off with pull-off hook - Pos. 19

21 - Light-alloy rim

- 6.5J x 16, ET 50

ŠKODA



Protected by copyright. Copying for private or commercial purposes, in part or in whole, is not permitted unless authorised by ŠKODA AUTO A. S. ŠKODA AUTO A. S. does not guarantee or accept any liability with respect to the correctness of information in this document. Copyright by ŠKODA AUTO A. S. ©

Fitting position of the adhesive wheel weights

a - 18 +1 mm

1 - Adhesive wheel weight on the outside of the rim

2 - Adhesive wheel weight on the inside of the rim

Glue balancing weights:

- self-adhesive
- max. 60 g allowed per rim flange
- perform the glueing at room temperature
- Remove any dirt and grease from the point to be glued on the light alloy rim, e.g. with cleaning solution -D 009 401 04-
- Remove the protective foil
- Do not touch if necessary do not clog up with dirt the adhesive surface
- Stick balancing weights onto the specified surfaces

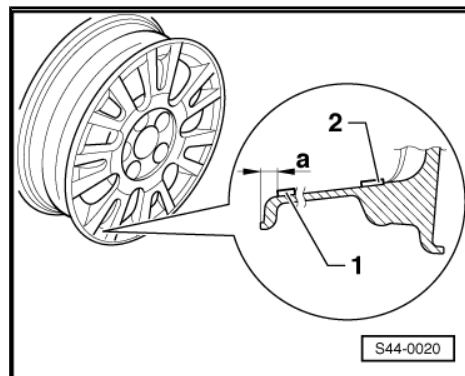

13.6 Wheel with a light alloy rim 7J x 17

Note

- ◆ The light alloy rim and wheel trim cap may differ from the figure.
- ◆ The contact surface tread may differ from the shown contact surface tread.

1 - Tyres

- tread bound by the direction of rotation

2 - Tyres

3 - Light-alloy rim

- 7J x 17, ET 54

4 - Light-alloy rim

- 7J x 17, ET 50

5 - Light-alloy rim

- 7J x 17, ET 54

6 - Light-alloy rim

- 7J x 17, ET 54

7 - Light-alloy rim

- 7J x 17, ET 54

8 - Light-alloy rim

- 7J x 17, ET 54

9 - Wheel bolt, anti-theft 120 Nm

- M14 x 1.5 x 27.5

10 - Cap

- for anti-theft wheel bolt - Pos. 9
- pull off with pull-off shackle - Pos. 13

11 - Adapter for anti-theft wheel bolt

- included in tool kit
- Master set for wheel bolts -T40004- or -T10101-

12 - Wheel trim cap

- can only be removed once the wheel has been removed
- removing and installing

Note

Do not use a pull-off hook or other tools, e.g. screwdriver as this could damage the wheel trim cap.

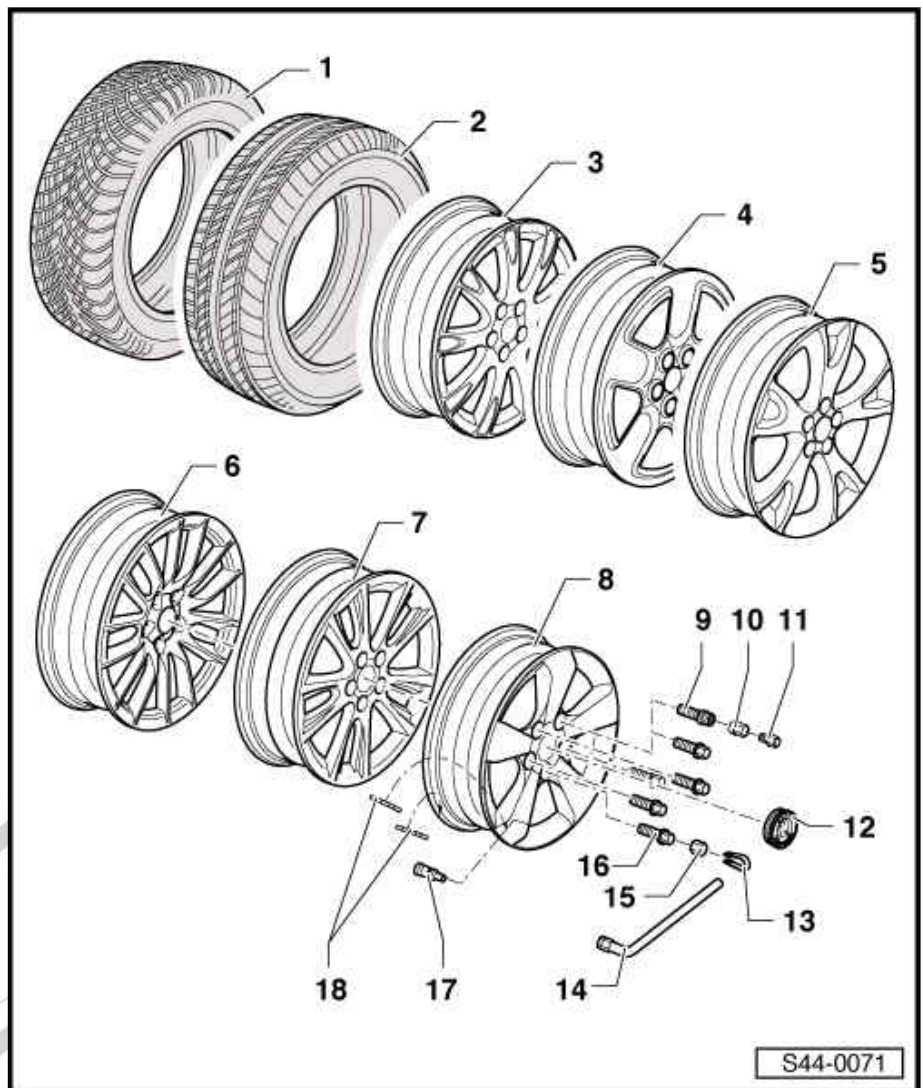

Removing:

Push the wheel trim cap towards the outside from the inside of the rim.



Installing:

Push-in the wheel trim cap from the outside of the rim, audible click.

13 - Pull-off shackle

- included in tool kit

14 - Wheel bolt key

- included in tool kit

15 - Cap

- for wheel bolt - Pos. 16
- pull off with pull-off shackle - Pos. 13

16 - Wheel bolt, 120 Nm

- M14 x 1.5 x 27

17 - Valve

- Assignment ⇒ Electronic Catalogue of Original Parts

18 - Adhesive wheel weights

- max. 60 g allowed per rim flange
- Fitting position and glueing procedure of the self-adhesive balancing weights ⇒ [page 92](#)

Fitting position of the adhesive wheel weights

a - 18 +1 mm

- 1 - Adhesive wheel weight on the outside of the rim
- 2 - Adhesive wheel weight on the inside of the rim

Glue balancing weights:

- self-adhesive
- max. 60 g allowed per rim flange
- perform the glueing at room temperature
- Remove any dirt and grease from the point to be glued on the light alloy rim, e.g. with cleaning solution -D 009 401 04-
- Remove the protective foil
- Do not touch if necessary do not clog up with dirt the adhesive surface
- Stick balancing weights onto the specified surfaces

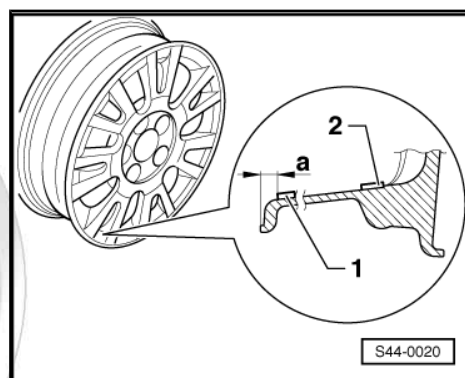

purposes, in part or in whole, is not permitted unless authorised by ŠKODA AUTO A. S. ŠKODA AUTO A. S. does not guarantee or accept any liability with respect to the correctness of information in this document. Copyright by ŠKODA AUTO A. S. ©

13.7 Wheel with a light alloy rim 7,5J x 18



Note

- ◆ The light alloy rim and wheel trim cap may differ from the figure.
- ◆ The contact surface tread may differ from the shown contact surface tread.

1 - Tyres

- tread bound by the direction of rotation

2 - Tyres

3 - Light-alloy rim

- 7,5J x 18, ET 51

4 - Light-alloy rim

- 7,5J x 18, ET 51

5 - Wheel bolt, anti-theft 120 Nm

- M14 x 1.5 x 27.5

6 - Cap

- for anti-theft wheel bolt - Pos. 5
- pull off with pull-off shackle - Pos. 9

7 - Adapter for anti-theft wheel bolt

- included in tool kit
- Master set for wheel bolts -T40004- or -T10101-

8 - Wheel trim cap

- can only be removed once the wheel has been removed
- removing and installing



Note

Do not use a pull-off hook or other tools, e.g. screwdriver as this could damage the wheel trim cap.

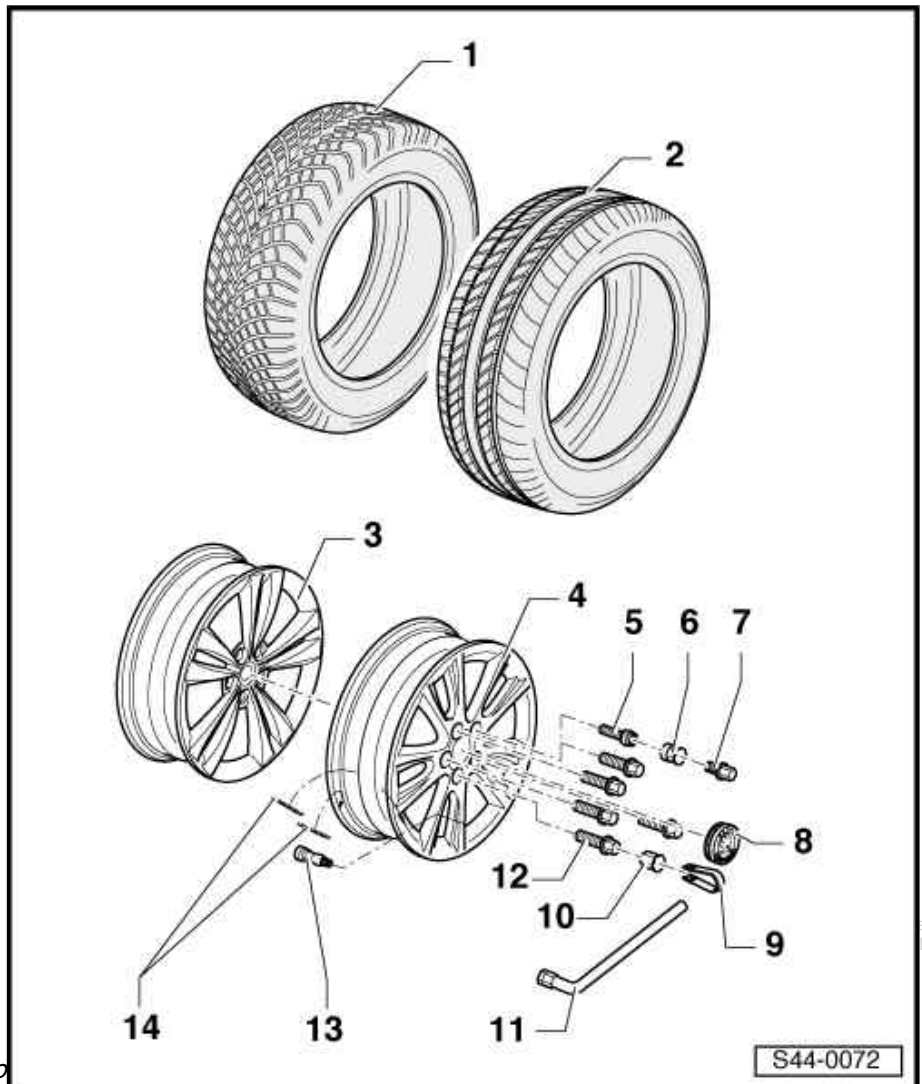

Removing:

Push the wheel trim cap towards the outside from the inside of the rim.

Installing:

Push-in the wheel trim cap from the outside of the rim, audible click.

9 - Pull-off shackle

- included in tool kit

10 - Cap

- for wheel bolt - Pos. 12
- pull off with pull-off shackle - Pos. 9



11 - Wheel bolt key

- included in tool kit

12 - Wheel bolt, 120 Nm

- M14 x 1.5 x 27

13 - Valve

- Assignment ⇒ Electronic Catalogue of Original Parts

14 - Adhesive wheel weights

- max. 60 g allowed per rim flange
- Fitting position and glueing procedure of the self-adhesive balancing weights ⇒ [page 94](#)

Fitting position of the adhesive wheel weights

a - 18 +1 mm

1 - Adhesive wheel weight on the outside of the rim

2 - Adhesive wheel weight on the inside of the rim

Glue balancing weights:

- self-adhesive
- max. 60 g allowed per rim flange
- perform the glueing at room temperature
- Remove any dirt and grease from the point to be glued on the light alloy rim, e.g. with cleaning solution -D 009 401 04-
- Remove the protective foil
- Do not touch if necessary do not clog up with dirt the adhesive surface
- Stick balancing weights onto the specified surfaces

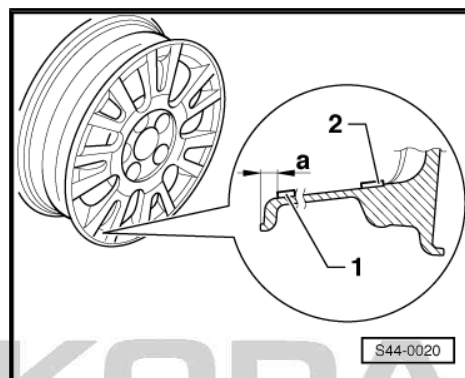

13.8 Spare wheel



Note

- ◆ Because of design variations the steel rims may differ from the figure.
- ◆ The contact surface tread may differ from the shown contact surface tread.

1 - Tyres

- for steel rim - Pos. 3

2 - Valve

- Assignment ⇒ Electronic Catalogue of Original Parts

3 - Steel rim

- 3,5J x 18, ET 25
- with a danger signal above the permissible high speed (80 km/h; 50mph)
- Spare wheel with light alloy rims 6.5J x 16 (as optional equipment)

4 - Tyres

- for steel rim - Pos. 5

5 - Steel rim

- 6.5J x 15 ET 47
- with a danger signal above the permissible high speed (80 km/h; 50mph)
- Spare wheel with light alloy rims 6.5J x 15

6 - Valve

- Assignment ⇒ Electronic Catalogue of Original Parts

7 - Tyres

- for steel rim - Pos. 8

8 - Steel rim

- 6.5J x 16 ET 50
- with a danger signal above the permissible high speed (80 km/h; 50mph)
- Spare wheel with light alloy rims 7J x 17 and 7.5J x 18

9 - Valve

- Assignment ⇒ Electronic Catalogue of Original Parts

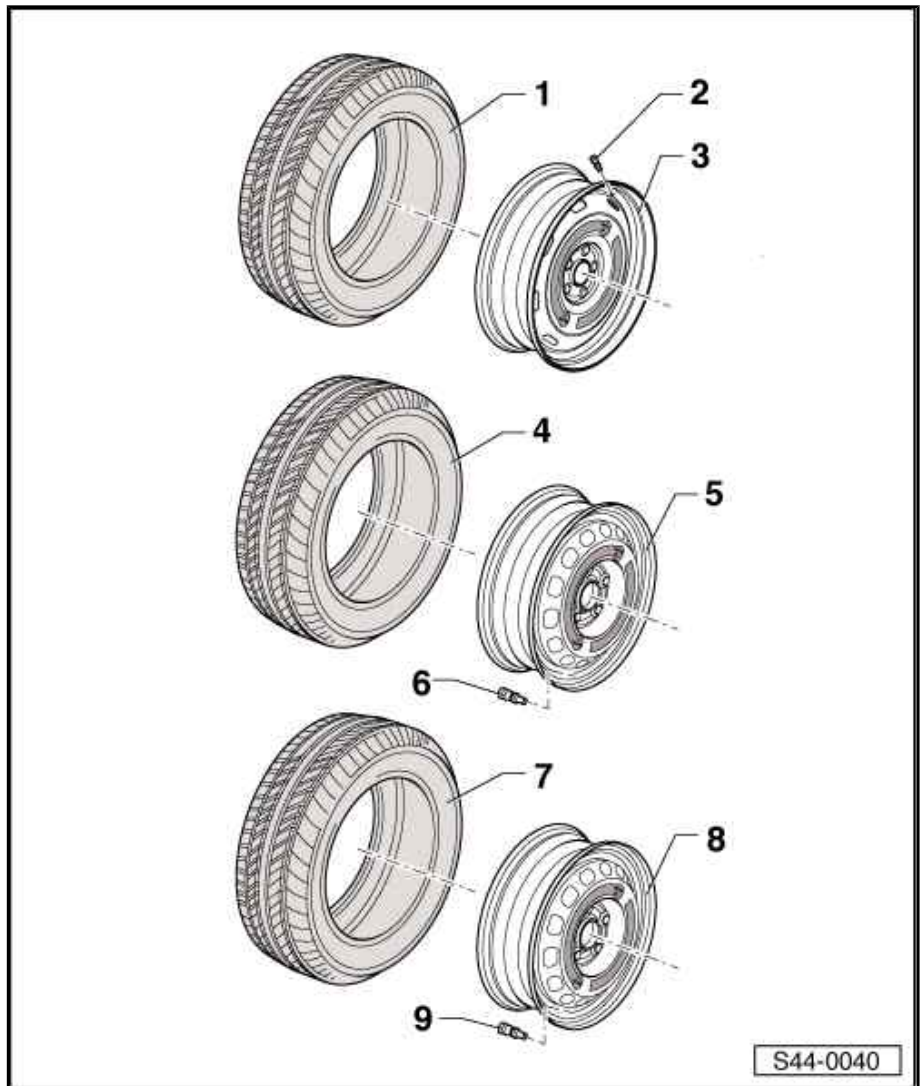

Protected by copyright. Copying for private or commercial purposes, in part or in whole, is not permitted unless authorised by ŠKODA AUTO A. S. ŠKODA AUTO A. S. does not guarantee or accept any liability for errors or omissions. Copyright by ŠKODA AUTO A. S.